

# CAN Translator Guide

ThunderStruck Motors - v3.2 October 2023

## Overview

### Introduction

The TSM Canbus Translator system consists of four main parts: the controller or other source sending canbus information, the Canbus Translator with OBD2 connector, the OBD2 Bluetooth transmitter, and the display device or tablet. The ThunderStruck CAN Translator kit consists of the pre-programmed translator and a harness connecting to the OBD2 connector, depending on the requested system. A USB to serial cable is needed if configuration changes are desired, and is available for purchase.

The Translator receives canbus messages from a source and converts them to OBD2 format. Messages are then sent to a Bluetooth transmitter, which converts them for the display device. The Translator is typically used in conjunction with tablets or phones running Android (using Torque Pro) or iOS (using OBD Fusion), but will also work with a custom OBD2 connection. The Translator sends messages which are interpreted as a vehicle system. It can also send messages back to the source if needed, and can control a set of OEM DCDC converters. Contact Thunderstruck if your application is not covered here.

### Overall Procedure

The user purchases the Bluetooth transmitter and connects the Translator to power and the canbus source. The display configuration file for the specific source is downloaded from our website and then transferred to the directory holding custom PID information. The display app is configured manually by importing data from the configuration file and then building each display (gauge) needed and assigning each display to one of the custom PID entries from the downloaded file.

### Configuration Options

Sevcon OS only: TSM pre-configures the Sevcon controller to work with the Translator. See *Configuring Older Sevcon Controllers* below if your controller has not been pre-configured.

Translator: pre-configured for the controller/source by TSM, configuration file available for import

Display configuration file: See the *Display Configuration* section below.

DCDC Converter control options: Chevy Volt, Delphi

Source Options	Source Configuration
Sevcon Motor Controller	See <i>Configuring Older Sevcon Controllers</i> below
Nissan Leaf Motor Controller	No configuration required
Curtis Motor Controller	No configuration required

Display Options	Software	Transmitter Options
Android Phone, Tablet	Torque Pro (Google Play)	<a href="http://torque-bhp.com/wiki/Bluetooth_Adapters">torque-bhp.com/wiki/Bluetooth_Adapters</a>
iPhone, iPad (OS10+)	OBD Fusion (iOS app store)	<a href="http://www.obdsoftware.net/software/obdfusion">www.obdsoftware.net/software/obdfusion</a>
Other/Direct CAN	email TSM	email TSM

# Wiring Instructions

## Sevcon Controller

Your Sevcon controller will be configured for you if purchased TSM to send canbus data to the Translator. The wiring harness provided with the Translator plugs into the controller "Programming" connector and an OBD2 Bluetooth transmitter selected from the display options listed above. See the section *Configuring Older Sevcon Controllers* if you purchased your controller before 2020.

Once connections are made and the controller is powered ON, the tablet/phone app will have access to the custom PID data created by the Translator. See the diagram below for wiring details.

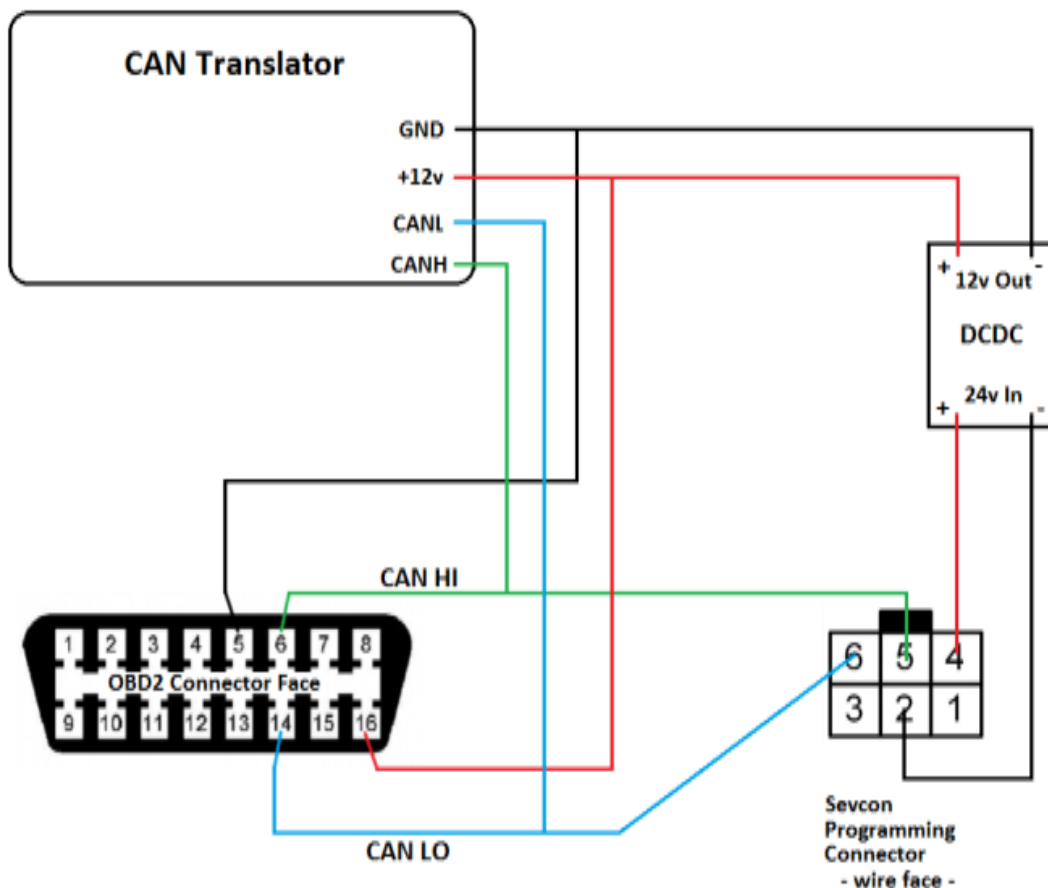

## Nissan Leaf Controller

The wiring harness provided for the Translator plugs into an OBD2 Bluetooth transmitter selected from the display options listed above.

Canbus HI and LO wires are connected to the VCU to controller canbus. 12v DC power is provided by the vehicle keyswitch bus. Note that the Leaf controller uses reversed colors for canbus HI and LO (example: blue is HI).

Once connections are made and the controller is powered ON, the tablet/phone app will have access to the custom PID data created by the Translator. See the diagram below for wiring details.

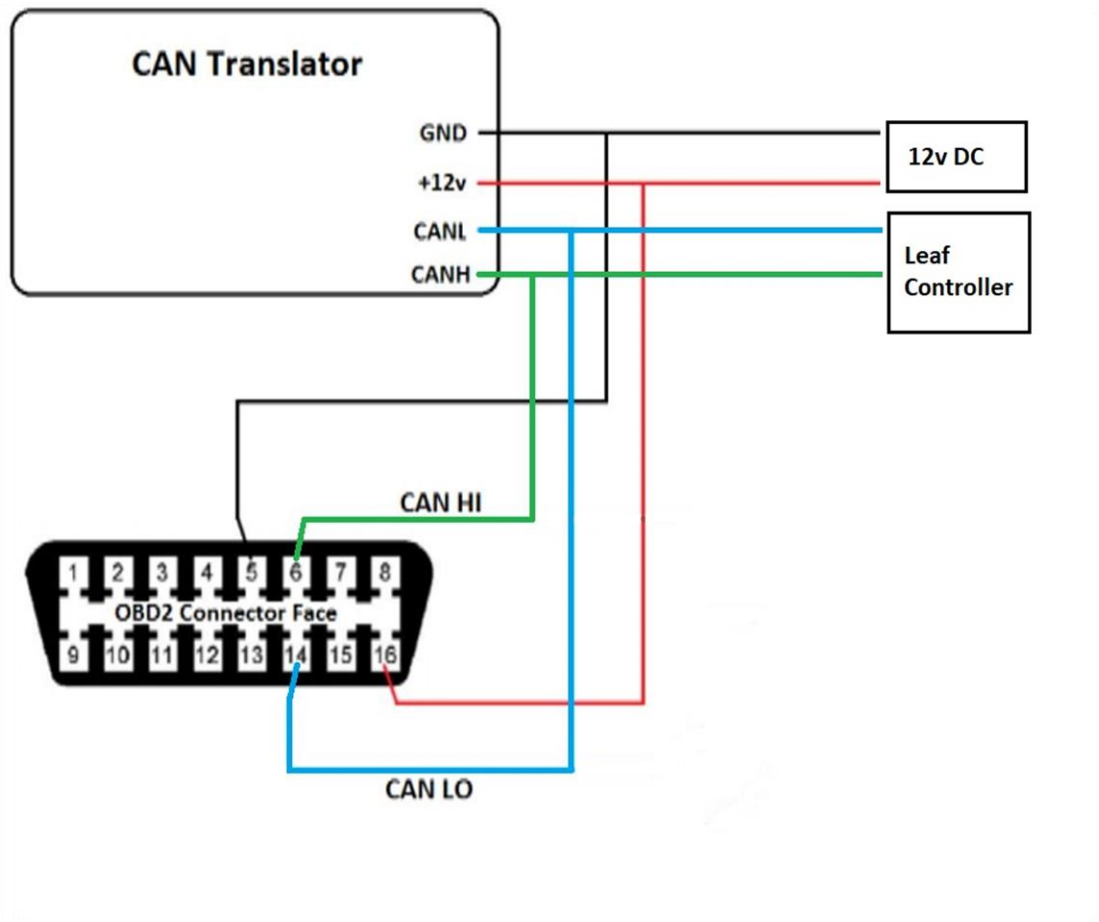

## Curtis Controller

The wiring harness provided for the Translator plugs into the Curtis controller “Programming” connector and an OBD2 Bluetooth transmitter selected from the display options listed above.

Curtis controllers sold prior to November 2020 may not include canbus wires at the 8-pin connector (below), and must be added for the Translator to function (contact ThunderStruck Motors for assistance).

Once connections are made and the controller is powered ON, the tablet/phone app will have access to the custom PID data created by the Translator. See the diagram below for wiring details.

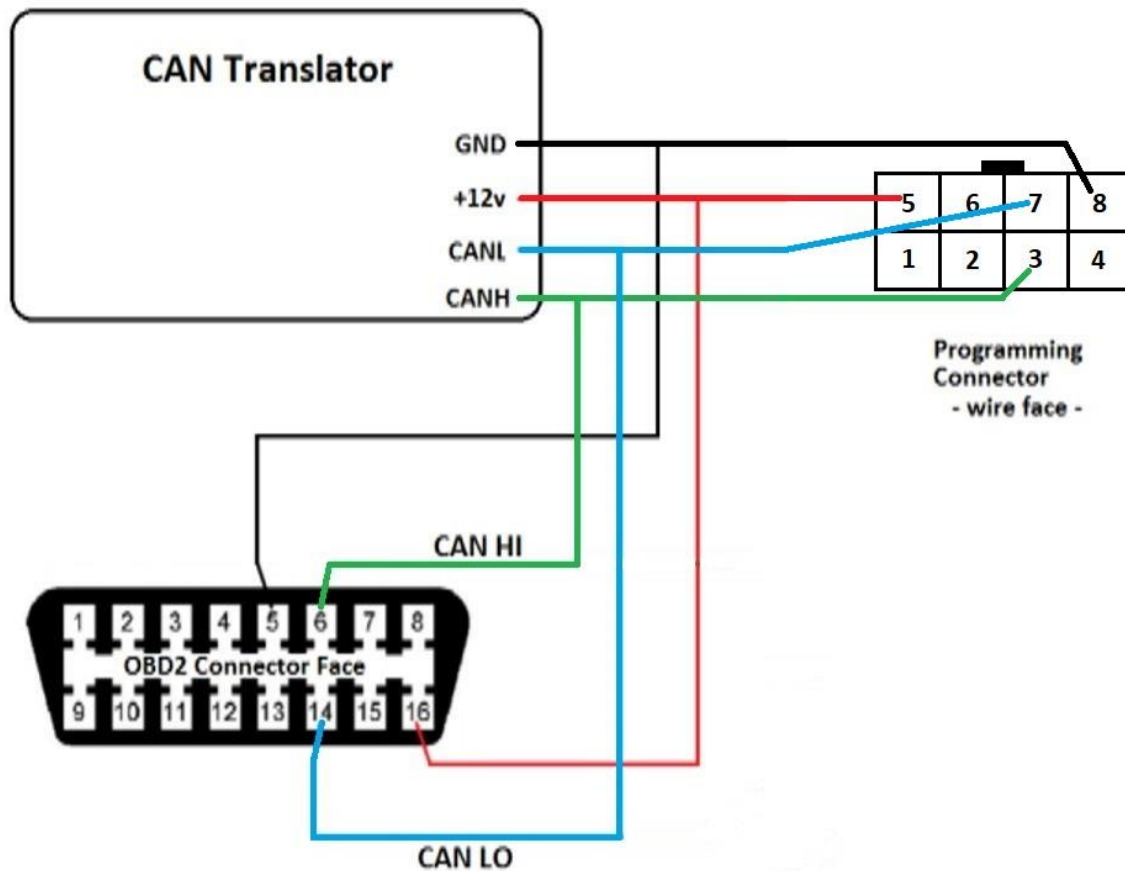

# Display Configuration

## Using Display Configuration Files

ThunderStruck Motors has prepared display data files set up with the essential OBD2 data for a few of the motor controllers we support.

First, download the files from our website to a computer or mobile device using the links here or on the website. These Comma Separated Values (CSV) files can be opened in a spreadsheet program if you want to preview them, however changes to the file contents are not recommended, and they must maintain the CSV format. Follow the instructions below based on the application type (Torque Pro or OBD Fusion typically) to upload the file into your display device.

Sevcon Torque App Configuration File

[www.thunderstruck-ev.com/images/companies/1/Display-Sensor/Sevcon-PID-20220920.csv](http://www.thunderstruck-ev.com/images/companies/1/Display-Sensor/Sevcon-PID-20220920.csv)

Curtis Torque App Configuration File

[www.thunderstruck-ev.com/images/companies/1/Display-Sensor/Curtis-PID-20220916.csv](http://www.thunderstruck-ev.com/images/companies/1/Display-Sensor/Curtis-PID-20220916.csv)

Leaf Torque App Configuration File

[www.thunderstruck-ev.com/images/companies/1/Leaf-PID-20201113.csv](http://www.thunderstruck-ev.com/images/companies/1/Leaf-PID-20201113.csv)

Knowledge of your device file management system is essential to complete the upload and import the data into your display application.

## Torque Pro Setup (for Android devices)

The "Torque Pro" application installed on an Android tablet (or phone) works well for many customers. This app receives Bluetooth signals containing instrumentation data ready to be assigned to various gauges (called displays) you will create in the app.

A display configuration file is uploaded onto the tablet (see above). It is then imported into Torque Pro, preparing a "custom PID" (with labels and equations) for each display option. This will help you get to the point where you are building your "displays" or gauges on the tablet screen.

After installing Torque Pro, take the following steps to download and import the data file into the application. These steps are based on a tablet running the Android OS.

1. Connect via USB to your tablet using a Windows computer. Download a file to that computer from our website after navigating to the following location:  
Instrumentation/Can Translator for Sevcon/Curtis/Leaf
2. Look for a link on that page entitled: [your controller name] "Torque App Config File"
3. Download the [your controller name]-PID.csv data file.
4. Transfer the file to your tablet under the following directory on the display:  
Internal shared storage\.torque\extendedpids\

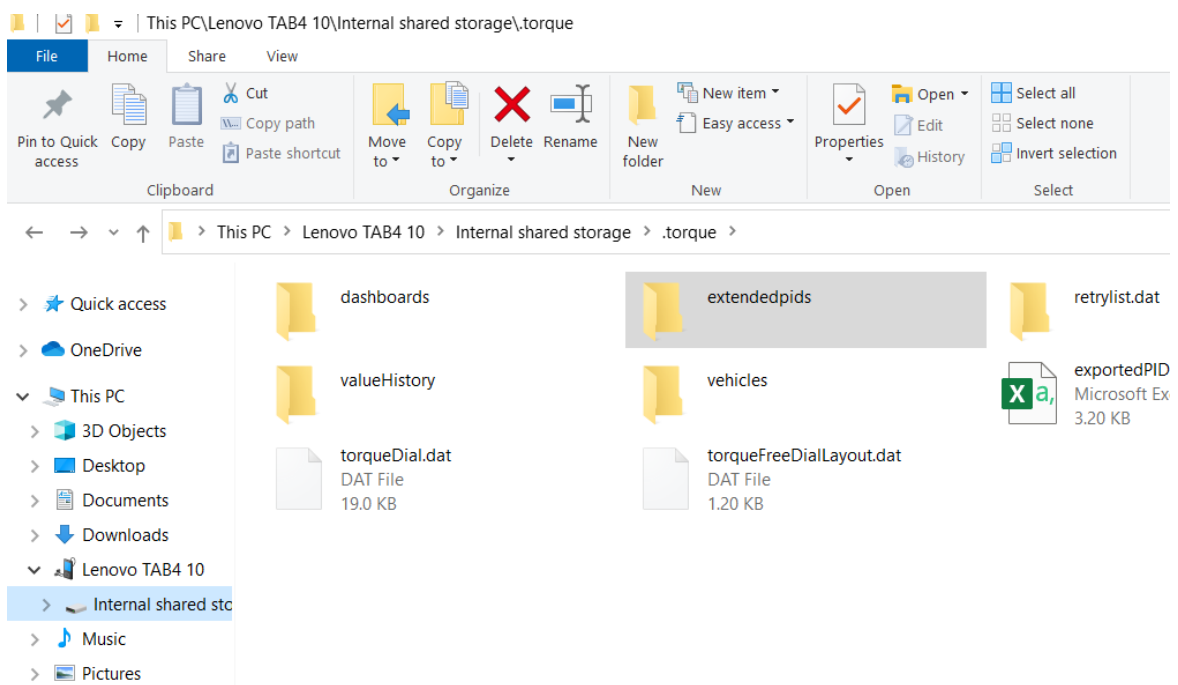

5. If the file does not end up in that directory, use the tablet's file manager to move it. Touch and hold on the file name until a move/copy option appears.
6. Open Torque Pro on your tablet, click on the "gear" icon in the lower left and select "settings." Then select the option "Manage extra PIDs/Sensors." (see screenshots below)

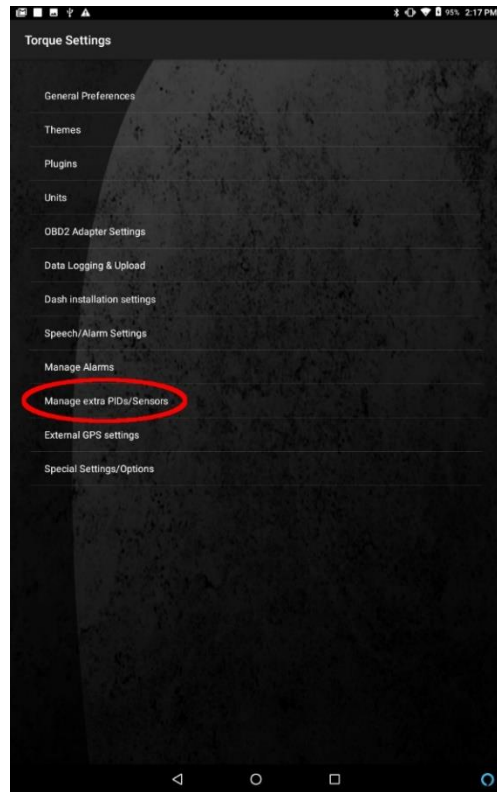

7. In the upper right-hand corner of that list, you will see some dots suggesting a menu list - touch on that, and then select the option "add predefined set."
8. You will see the file name you transferred in the list. Select that, and complete the process.

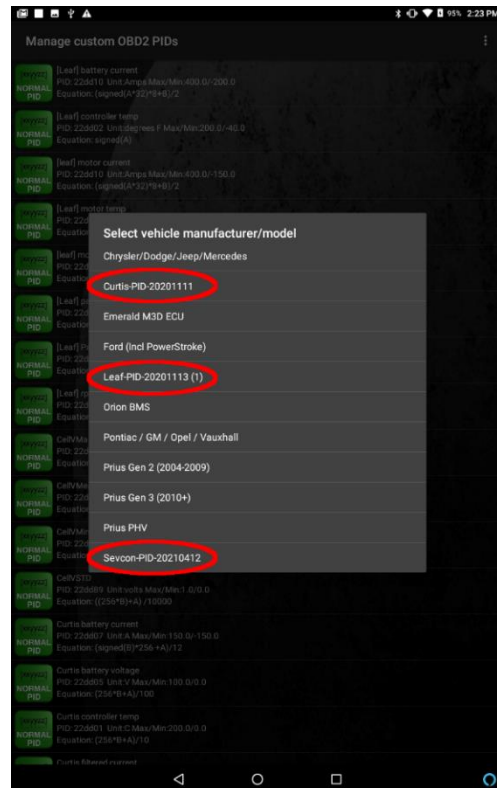

9. Now, in your “Manage extra PIDs/Sensors” list, you will see some new values.

Next, you will assign the new “PIDs/Sensors” to displays you create in Torque Pro.

1. Start up the Torque Pro app and select the "Realtime Information" option in the first screen.
2. Touch and hold in a blank space, then select “Add display.” Select one of the listed display types.
3. Review the long list of PID options, and locate the ones identified by the controller type from your project.
4. From the option list, select the custom PID associated with the display/gauge you are creating.

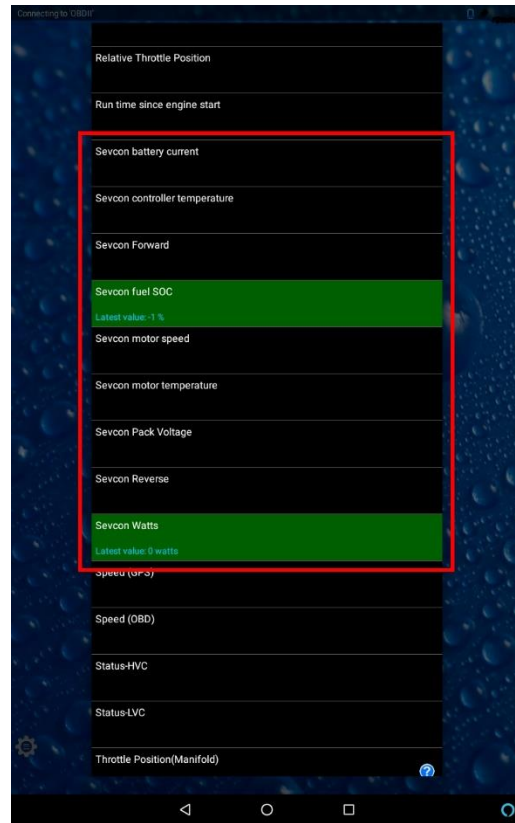
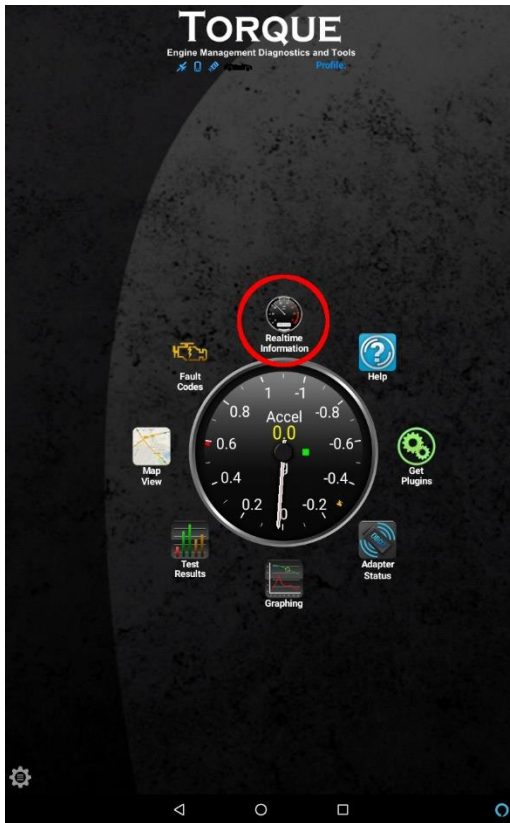

5. Perform this one at a time for the desired display/gauges.
6. Displays can be edited by touch/holding on any display/gauge until an option list shows – select “Display Configuration” to edit or test.
7. It is also possible to add displays based on the internal 12v supply voltage and GPS information in your tablet.



## OBD Fusion Setup (for iOS devices)

OBD Fusion is an application reported to work well with iOS devices. OBD Fusion accepts CSV data imports and has display types like Torque Pro. See the web link above for applicable OBD2 Bluetooth transmitter options.

Install OBD Fusion on your iOS device from the App Store. Using your PC (Mac or Windows), download the *display configuration file* from the Thunderstruck Canbus Translator webpage for the controller being used in your project. Then take the following steps to transfer this file to your iOS device using iTunes on your PC.

1. Connect iOS device to PC via USB connection
2. Open iTunes on PC, and select the device icon (phone) in the upper left of window.
3. Select "File Sharing" in the left column
4. Select the "OBD Fusion" app from the app list
5. Scroll to the bottom of the file list for the app
6. Click the "Add File..." button
7. Navigate to the .csv file you downloaded from the ThunderStruck website
8. Select the file and click "Open" (this copies the file)
9. Verify the .csv file is now in the iTunes list (scroll up if needed)
10. Click "Done" to close the file sharing window
11. Close iTunes and unplug your iOS device

Import the PID data into OBD Fusion using the following steps. When completed, you will have a group of custom PIDs under the specified manufacturer name.

1. In your iOS device open the OBD Fusion app
2. Click Settings
3. Click User-Defined PIDs
4. Accept the warning "OK"
5. Click the "Menu" word at the top right of the screen
6. Click "Import from file" in the list and enter a name for the manufacturer of your controller (Sevcon, Curtis, Leaf, UQM, etc.) - click "OK"
7. Select the user-defined PIDs you want for your display (Leaf options shown)
8. The User-Defined PIDs section will now show the selected PIDs under the manufacturer name entered above
9. Click "Back" at the top to return to the home page

The screenshots on the following page give an overview of this procedure. These were recorded from an iPhone 7.

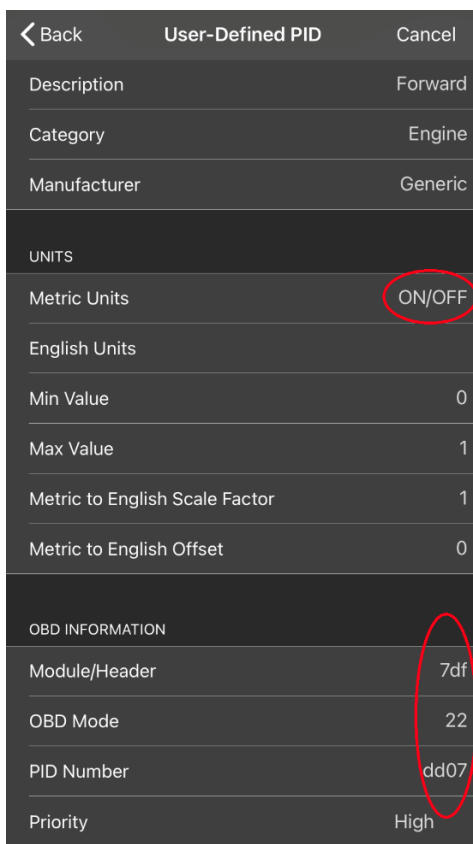
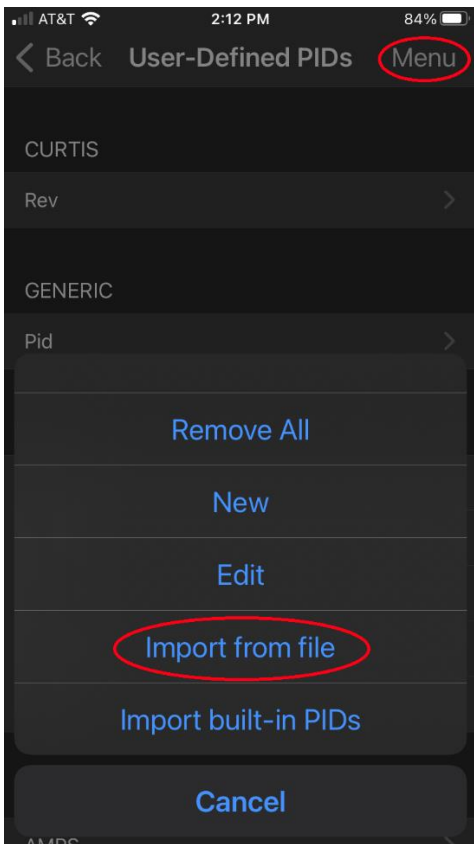
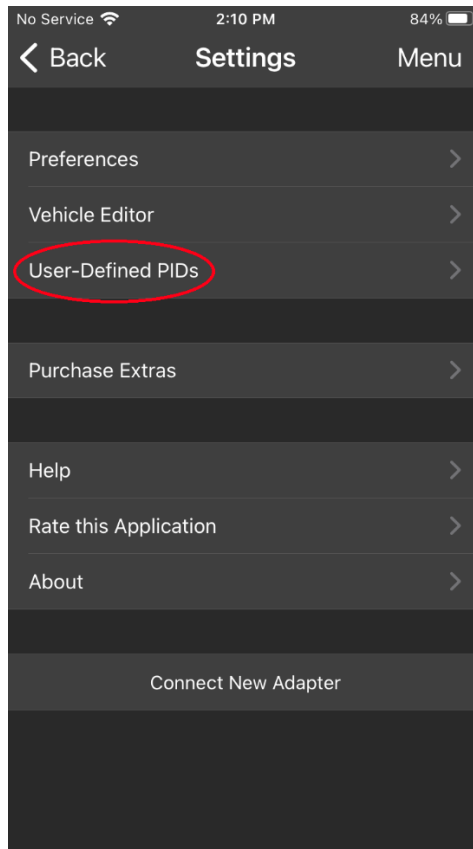
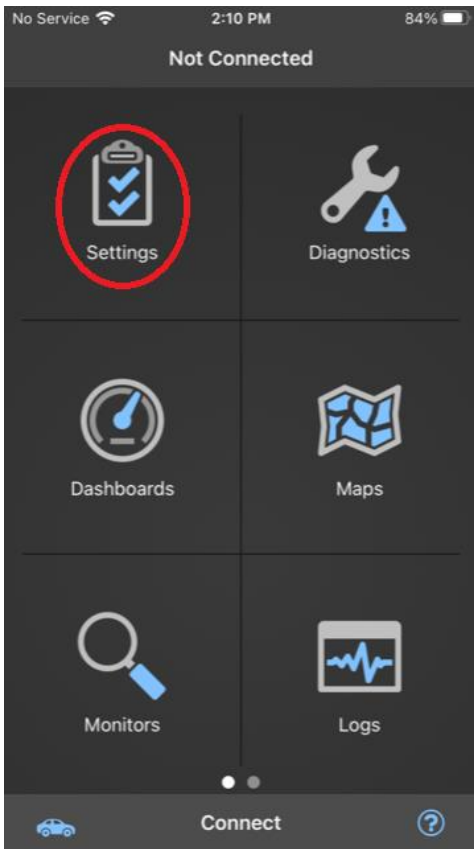

The next step is to create a display for each PID, but before this, PID values must be edited – this corrects some differences between OBD Fusion and Torque Pro data imports.

In the User-Defined PIDs page (screenshot above), select one of the desired PIDs, then make the following PID configuration changes (repeat for each PID – see example screenshot above):

1. Model/Header: Change this to 7df (remove the leading "@")
2. OBD Mode: Change this to 22
3. PID Number: Remove the leading number 22, but leave the rest (example result: dd06)

Return to the home screen and select *Dashboards*. Click the Menu link in the upper right and select *Add Display*. Follow the selection options for display type and options for that specific PID. In the last screen, you will assign the desired User-Defined PID to that display.

Note: In order to create a button indicator (like F for Forward direction), then you will set the *Units* (English or Metric) to be *ON/OFF* in the User-Defined PID screen (screenshot above).

Here is a link to more info on the OBD Fusion user-defined PIDs:

<https://obdsoftware.force.com/s/article/user-defined-pids>

Once configured, and the Can Translator and transmitter are powered on, enter the home screen and click *Connect*.

If the OBD2 transmitter is not connecting, be sure your iOS device Bluetooth is turned on, and in the Bluetooth section of *Settings*, make the connection to the ELM (or other) device there before going into the OBD fusion app.

From within OBD Fusion, Navigate to *Settings/Preferences/Communications*, note the *Type* option. Set this as needed. If you have a generic LE transmitter, select Bluetooth LE, and let OBD Fusion pair to the transmitter. If you have a OBDLink MX+ then you must pair your adapter in the iOS Bluetooth settings.

## Translator LED Indications

The Canbus Translator shows a flashing green light when powered.

- Two flashes per second is expected during normal operation.
- During a firmware upgrade, the light may be either steady ON or OFF.
- No light during normal operation suggests 12v power is disconnected, or an internal fault.

## Thunderstruck Support

[connect@thunderstruck-ev.com](mailto:connect@thunderstruck-ev.com)

(707) 578-7973

# Advanced Features

## Canbus Translator User Interface Configuration

A user interface is available for making any needed changes to the Translator system. This requires a specific USB to serial cable and a computer terminal application like Putty or Coolterm. See the [ThunderStruck-ev.com](http://ThunderStruck-ev.com) Serial Port Utilities doc link at the bottom of this document for installation instructions. The serial cable is an option for purchase on the CAN Translator page.

### Learning the Commands

The Translator uses a simple command line interface. Command examples are shown with shortcuts in upper case for reference, but the user interface is not case sensitive. The following help commands list information about setting values in the user interface.

HELP – lists user interface commands

SEt – lists specific command details for making configuration settings

### Setting and Deleting “Rules”

*Rules* are Translator records configuring receive (COR) and transmit (TXR) information in byte form to be used by the Translator. The following is a SEt command definition and an example of adding a COR to the system.

#### COR CanOpen Rule

```
set cor <n> <inSID> <iIDX> <outSID> <PID> <d1>[<d2>]
```

<n> - rule number

<inSID> - canOpen SID in hex

<iIDX> - optional i[index]s[sub-index]

<outSID>- ODBII SID in hex

<PID> - ODBII PID in hex

<dn> - ODBII data translated from CanOpen message

<dn> = <byten>[:<mask>]

<byten> = B1|B2|B3|B4|B5|B6|B7|B8

<mask> = bitmask entered in hex

```
set cor <n> none - to delete
```

Examples:

```
set cor 1 271 7e8 9 b3 b4
```

```
set cor 2 271 7e8 10 b2:2
```

```
set cor 3 271 i5100s02 7e8 9 b3 b4
```

*Transmit Rules* (TXR) are records sent to the source equipment as needed by the system, for instance during startup or to request desired information. The following is a TXR command definition and an example of adding a TXR to the system. An example of deleting COR and TXR entries is also included.

TXR - Transmit Rule

```
set txr <n> <ms/user> <eid/sid> [<d1>[<d2>[<d3>[<d4>[<d5>
    [<d6>[<d7>[<d8>]]]]]]]]]
```

<n> - rule number

<ms/user> - repeat timer in milliseconds

<eid/sid> - CAN EID or SID in hex

<d1..dn> - 0 to 8 data bytes, in hex

set txr <n> none - to delete

Example:

```
set txr 1 250 1dd4512 23 01 00 00 00
```

```
set txr 2 user 601 2b 00 50 02 df 4b 00 00
```

## Setting Baud Rate

The Translator operates at various baud rates (kilobits per second) as required by the data source. Available settings are 125, 250 and 500 kb. The following command sets the baud rate to 500 kb. (canbr means "CAN baud rate")

```
set canbr 500
```

## Show and TRace Commands

SHow [<>|Version|Config] – displays system version or configuration. "Show" alone displays status. The following is a show configuration example for the Sevcon controller.

```
CANapp> sh c
```

```
canbr : 500kbps
```

```
tx rules : none defined
```

```
co rules : iSID iIDX oSID PID data (n)
```

```
1 : 0454 ---- 07e8 dd05 b1 b2 0 0 0
```

```
2 : 0271 ---- 07e8 dd02 b2 0 0 0
```

```
3 : 0411 ---- 07e8 dd04 b6 0 0 0
```

```
4 : 0271 ---- 07e8 dd01 b0 b1 0 0 0
```

```
5 : 0271 ---- 07e8 dd03 b3 b4 0 0 0
```

```
6 : 0454 ---- 07e8 dd06 b0:02 0 0 0
```

```
7 : 0454 ---- 07e8 dd07 b0:01 0 0 0
```

```
TRace [CANbus|OFF]
```

```
canbus - trace canbus messages (good for verifying connection)
```

```
off - disable all tracing
```

## Configuration Export/Import

The Translator can export a text record of the configuration settings which can be imported into a second Translator. This simplifies programming multiple devices and facilitates remote customer support.

From within the user interface, enter the command “dumpdb” and a list of hexadecimal values will display, appearing as an extended version of the following:

```
:020000040200f8  
:100000000000ffffffff04ff00ff8700ffff6f  
: ... (many additional lines of data)  
:00000001ff
```

Copy the entire string by selecting and copying all the rows, starting at the first colon (:) before the first short row and ending at the final character of the last short row (...1ff). The clipboard can then be saved in a text document (not a word processor file) for use later, or can be used immediately in another Translator user interface.

To import, power up the Translator device, click into the user interface and hit Enter to show the CANapp> prompt. With the configuration data already in the computer clipboard, hover over the interface window and right click (Ctrl click for Mac) to paste the contents into the window.

Use the enter key to show the CANapp> prompt, then type “show config” to verify the import.

## Configuring Older Sevcon Controllers

Users with Sevcon Gen4 controllers purchased from ThunderStruck prior to year 2020 may need to apply custom Can Translator configuration commands through the user interface. The following text file contains step by step instructions including “dumpdb” (see above) characters to streamline the process. This allows the Can Translator to modify SDO objects on the controller so it can receive data.

[www.thunderstruck-ev.com/images/companies/1/Display-Sensor/SevconSDO-Config-Web2023-1.txt](http://www.thunderstruck-ev.com/images/companies/1/Display-Sensor/SevconSDO-Config-Web2023-1.txt)

This is an advanced procedure, and can be reversed if needed. The serial cable mentioned above is required for this procedure. Contact ThunderStruck Motors if you need help with this configuration.

## Configuring DCDC converters

The Translator has been programmed to send control messages over canbus to the Chevy Volt and Coda Delphi DCDC converters. The following commands are used to enable and set the regulated output voltage for these devices.

DDTYPE - DCDC converter type

```
set ddtype [none|volt|delphi]
```

DDVOLTAGE- DCDC converter voltage

```
set ddvoltage <v> - enter volts and tenths (e.g., 13.6)
```

## Canbus Termination Resistor

Many canbus networks using the Translator function well without adding terminating resistors. In these cases, no action is needed. However, it is possible to add a termination to resolve communication issues by joining two jumper pads on the Translator circuit board. See the jumper at "CAN term" on the board to the right. A thin strand of copper wire has been soldered in place.



## System Upgrades

ThunderStruck Motors may periodically provide firmware upgrades for our Dilithium Designs devices. The Translator can be upgraded if needed by the user following the steps outlined in the Serial Port Utilities document at the following web address.

[http://www.thunderstruck-ev.com/images/companies/1/DD\\_SerialPortUtilities\\_v1.2.pdf](http://www.thunderstruck-ev.com/images/companies/1/DD_SerialPortUtilities_v1.2.pdf)