

Thunderstruck Motors Vehicle Control Unit v3.1

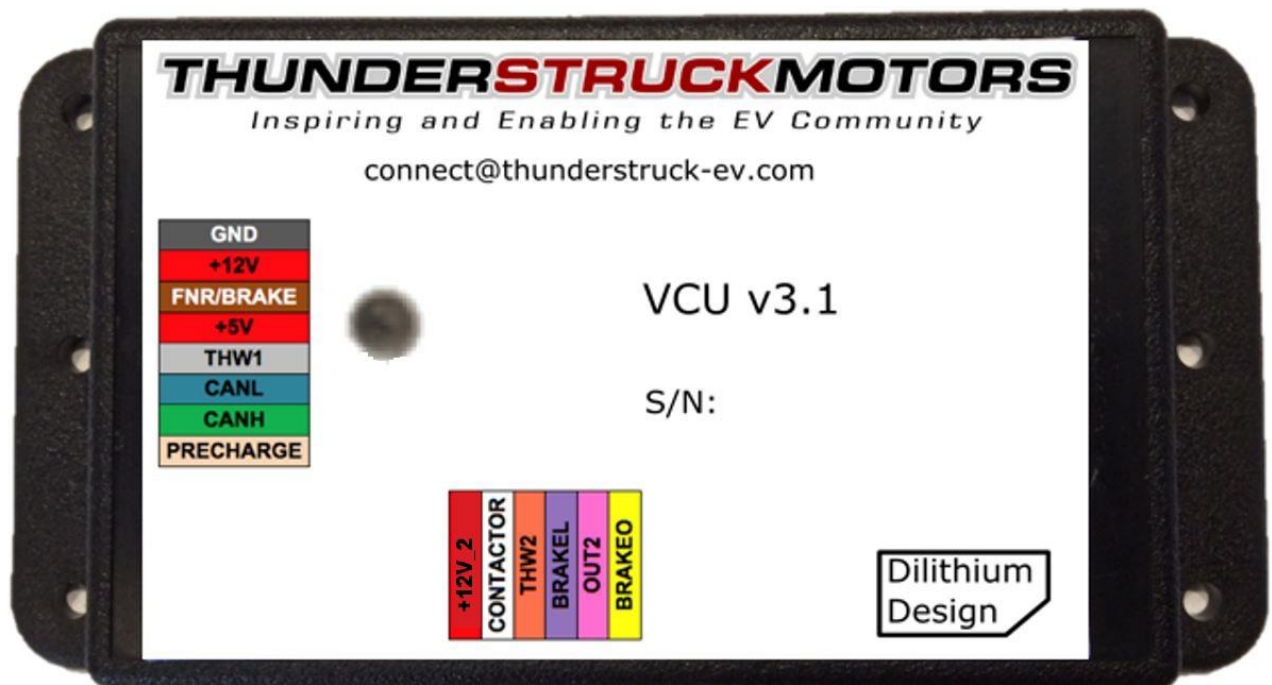

Document Revision 3.1.4

© 2018-2025 Dilithium Design

Contents

Overview	4
Installation and Wiring	5
VCU Accessory Kit.....	5
Mechanical	5
Power (GND, +12V, +12V_2)	7
CANH and CANL.....	7
Throttle (THW1, THW2)	7
PRECHARGE and CONTACTOR	8
FNR/BRAKE	9
BRAKEL (Brake Light Input) and BRAKEO (Brake Light Output).....	10
OUT2.....	10
ZE0 Leaf Inverter (EM61 Motor).....	11
ZE0 Inverter Connections	11
ZE0 Leaf Pack Connections	12
AZE0 Leaf Inverter (EM57 Motor)	13
AZE0 Leaf Inverter Connections	13
AZE0 and ZE1 Leaf Pack Connections	14
ZE1 Leaf Inverter (EM57 Motor).....	15
Nissan Leaf ZE1 Inverter Connections	15
Operation Information for all Leaf Inverters.....	16
Cooling	16
Leaf Inverter Operation.....	16
Common Issues	16
UQM and UQM Coda Inverter Setup.....	17
Inverter Configuration.....	17
UQM Inverter Cofiguration Examples.....	17
UQM High Voltage Wiring.....	19
UQM Low Voltage Connections.....	20
UQM Inverter/Motor Cooling	20
VCU Configuration	21
Serial Port Drivers	21
Throttle	21
Map	21
Brake	22

Motor / Inverter	22
DC/DC Converter.....	24
Diagnostics.....	24
measure.....	24
Trace.....	25
trace can	25
trace verbose	25
trace uc.....	25
Startup Diagnostics	25
Operation.....	27
Startup	27
Direction Switch.....	27
Throttle	27
Braking Regen.....	27
Idle Regen / Throttle Braking.....	28
Operation – Leaf (all versions).....	28
Operation – UQM.....	28
Operation – UQM Coda.....	29
LED	29
Firmware Upgrade.....	30
Serial Interface.....	30
Startup Banner.....	30
help.....	30
show <>.....	31
show version	32
show config.....	32
set	34
set <>.....	34
THROTTLE (thtype, thw1off, thw1max, thw2off, thw2max)	35
THROTTLE MAP (r1top, r2top, r1scale, r2scale)	36
BRAKE (brtype, broff, brmax).....	36
MOTOR/INVERTER (inverter, prechgminv, regenvmax)	36
MOTOR/INVERTER (maxtorque, maxrpm, maxrpmtorque, torquekneerpm, jerklm)	37
MOTOR/INVERTER (maxrpm2)	37
MOTOR/INVERTER Automatic Transmission (idletorque, idlerpm).....	37
MOTOR/INVERTER Regen Configuration (idleregen, brakeregen, deadspot)	37
enable / disable.....	37

Can Termination37

Neutral Wait.....37

Forward / Reverse Switch.....37

Forward / Neutral / Reverse Switch.....38

measure.....38

measure <>38

trace38

trace <>38

trace uc, can, verbose38

upgrade39

Warranty and Support.....40

Document History.....40

Figures

Figure 1 – VCU 3.1 System Diagram.....4

Figure 2 – VCU Enclosure6

Figure 3 – Push-In Connector.....6

Figure 4 – VCU 3.1 Connections7

Figure 5 – Single and Dual Wiper Throttle Wiring (example throttle pinouts shown)8

Figure 6 – PRECHARGE and CONTACTOR Wiring.....8

Figure 7 – Direction Switch Wiring after May 2021 - FR enabled on left, FNR enabled on right9

Figure 8 – Direction Switch Wiring (without the "FNR rework")9

Figure 9 – BRAKE Light Input and BRAKE Light Output Wiring10

Figure 10 – UQM Configuration – System Parameters Tab18

Figure 11 – UQM Configuration – Control Tab.....18

Figure 12 – UQM Configuration – Canbus Settings Tab18

Figure 13 – UQM Configuration – Canbus Settings Tab - Enables19

Overview

The Thunderstruck Vehicle Control Unit (VCU) converts analog throttle and brake inputs into CAN messages to control Nissan Leaf, Coda/UQM, or UQM PowerPhase® Inverters. This document describes how to install, configure, and troubleshoot the VCU.

This document applies to VCU 3.1 hardware, and supports features present in firmware versions 3.2.7 and newer. Although most information is applicable to previous VCU versions, archived manuals are available on request from Thunderstruck Motors if needed.

See below for a system diagram.

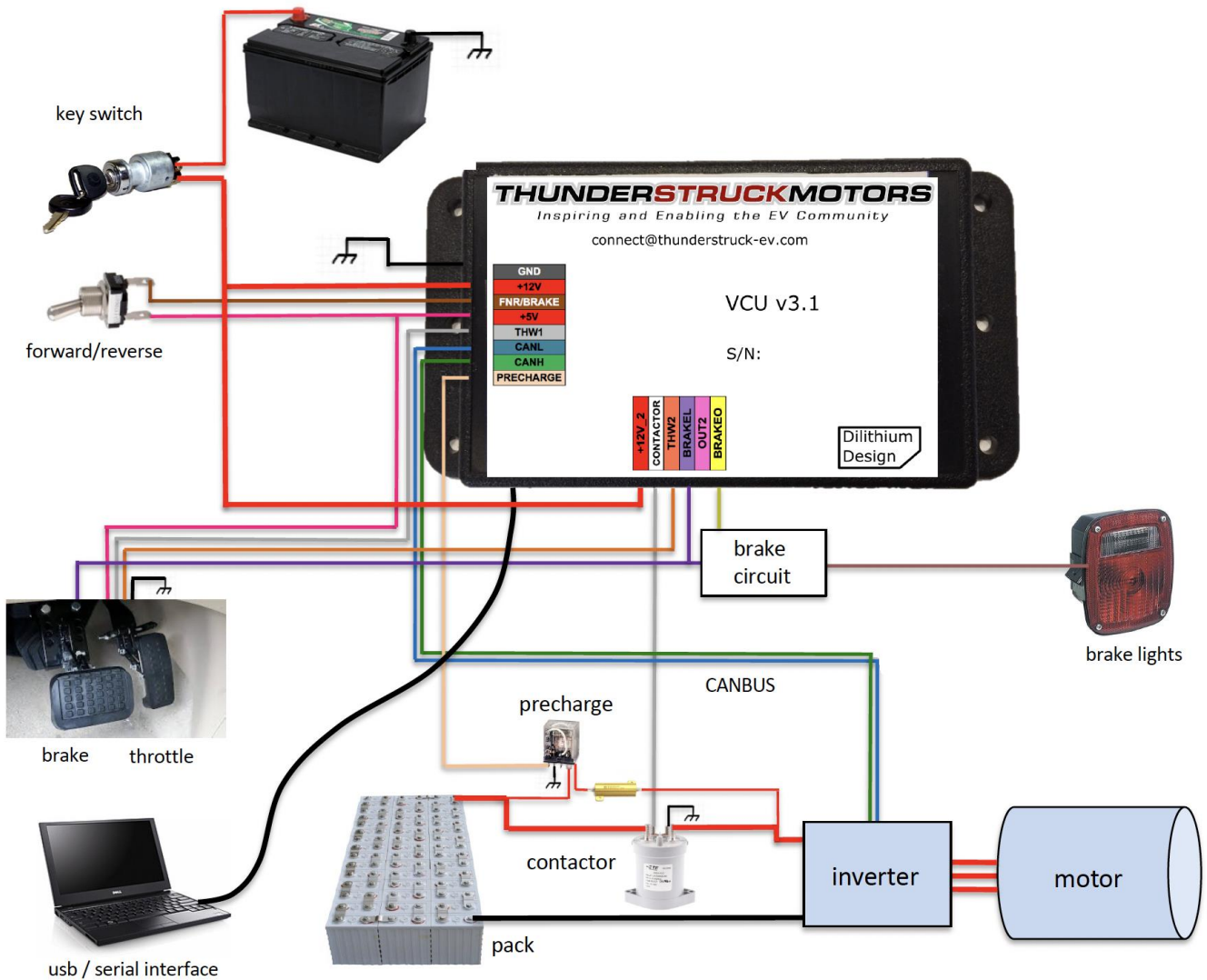

Figure 1 – VCU 3.1 System Diagram

The VCU has the following required interfaces:

- 12V Power, normally connected to an EV accessory battery through the Keyswitch.
- CAN, used to communicate between the VCU and Inverter.
- Throttle, which connects to a Hall or resistive throttle and determines the requested torque.

The VCU has the following optional interfaces:

- Precharge Control to enable a precharge relay.
- Contactor Control to enable the main contactor.
- Forward/Reverse (or Forward/Reverse/Neutral) input, to determine the direction of motor rotation for direct drive systems.
- Brake Switch, to request regeneration when the brake is applied.
- Brake Pressure Transducer, which can request variable amount of regeneration depending on brake pedal pressure.
- Brake Light output to turn the brake light on when there is braking regeneration.
- Optional output for controlling the reverse light circuit.

A serial port interface is required for configuration and debugging, but is not used during normal operation.

Installation and Wiring

Additional diagnostic and wiring information is available online on the VCU Manuals & Downloads tab. See the *VCU Troubleshooting Guide* and *VCU Output and Input Wiring Diagrams* documents.

VCU Accessory Kit

The accessory kit provides many of the essential components required for a faster build at reasonable price. If the VCU was purchased with an Accessory Kit, the following parts are included:

- Throttle (single wiper hall type)
- Main contactor with “economized” 12v coil (low holding current)
- Precharge relay and power resistor
- A prewired harness which connects the VCU to the included parts

Equipment like BMS, Charger, DC/DC converter and display are separate items which can be ordered through the Thunderstruck website.

Mechanical

The VCU is housed in a Serpac WM010I enclosure, a 4.61 x 2.32 x 0.6 plastic enclosure with mounting flanges. The enclosure datasheet and drawings can be found at the serpac.com website.

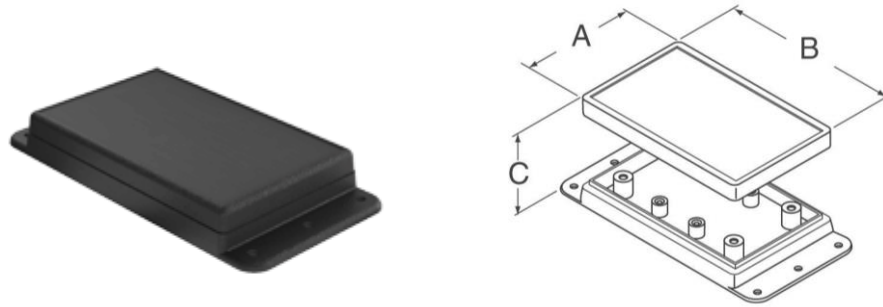

Figure 2 – VCU Enclosure

The enclosure has two connectors: “Connector A” and “Connector B”, a 3.5 mm serial port jack, and an LED. The connectors are “push-in” connectors which accept 20-24 gauge stranded or solid wire. For best fit and to allow insulation to be recessed into the connector, stranded 20 or 22 gauge TXL wire is recommended. To make a connection, strip the wire back slightly less than 1/4”. Twist the wire end to gather the strands, and insert fully. Be sure that all strands of wire get correctly inserted to prevent shorting between adjacent wires.

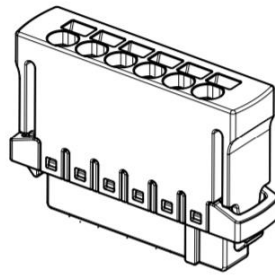

Figure 3 – Push-In Connector

Removing wires from the connector requires a removal tool, which is supplied with the VCU kit. Insert the tool into the associated rectangular slot above the wire and wiggle it in. This will collapse the spring holding the wire, allowing it to be removed.

The connector part numbers are

- 8p Connector A Harting 14310813101000
- 6p Connector B Harting 14310613101000

The VCU 3.1 connector pinouts are given below:

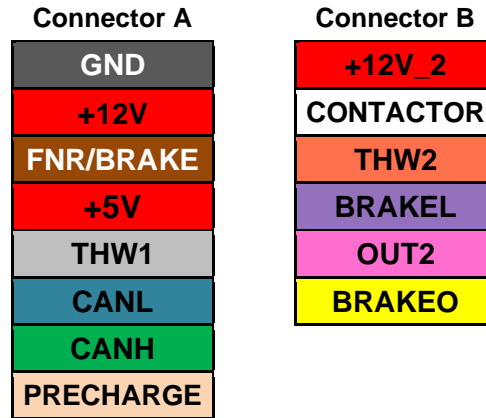

Figure 4 – VCU 3.1 Connections

Power (GND, +12V, +12V_2)

+12V and **GND** are Power Inputs and should be connected to a source of 11V-14V power (12V nominal). These inputs are usually to Keyswitch Input and Chassis Ground. The **+12V_2** input on Connector B supplies current for the contactor.

CANH and CANL

CANH and **CANL** are the CAN connections. The CAN network must connect the Inverter to the VCU. The CAN baud rate in the VCU is fixed at 500kbps and all devices must operate at this rate. Adding components from other manufacturers to the canbus network may interfere with communication, and is not recommended.

A CAN network is a daisy-chain, multistation network. Normal CAN network wiring guidelines should be followed. CAN wiring should be kept short and the conductors should be twisted. Wiring should be placed away from electromagnetic interference such as the motor, and parallel runs next to EV traction cabling should be avoided.

The CAN network must be terminated on both ends of the string by 120ohm termination resistors. Wiring stubs to non-endpoint nodes should be kept as short as possible, ideally less than a few inches. The VCU contains an internal, configurable, CAN termination resistor. By default, this termination is enabled, however this may be disabled in the user interface.

Throttle (THW1, THW2)

THW1 and **THW2** are throttle wiper inputs. By default, the VCU assumes that a single wiper throttle and only **THW1** is used. Dual wiper throttles are used as a safety feature to prevent a single point of failure. If configured, the VCU firmware requires that the two wipers track each other and provide consistent readings.

A dual wiper throttle is configured with the command **set thtype dhall**. Both throttle outputs have configured high and low settings (**thw1off**, **thw1max**, **thw2off**, **thw2max**), which determine the limit values for each wiper.

Hall throttles require power and ground connections to operate. If the throttle uses +5V power, this may be provided by the VCU **+5v** output. Both **THW1** and **THW2** inputs expect values in the range of 0 to 5v.

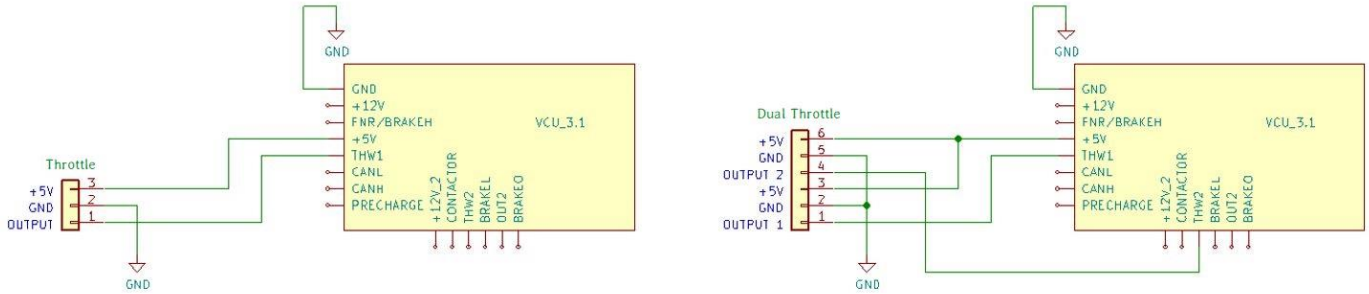

Figure 5 – Single and Dual Wiper Throttle Wiring (example throttle pinouts shown)

PRECHARGE and CONTACTOR

The VCU supports **PRECHARGE** and **CONTACTOR** outputs. The **PRECHARGE** output is switched to +12V when active and is rated to 400ma. The **CONTACTOR** output is switched to +12V and is rated to 1.5A. Note that the current for the main contactor is supplied on the +12V_2 input, which is connected to a +12V input capable of sourcing enough current for the main contactor. If the main contactor requires more than 1.5A then an intermediate relay is required. See Figure 6 for suggested wiring.

Precharging is required to reduce current surge into the inverter capacitors when the main contactor closes. The precharge relay is closed when 12v is applied to the VCU. This allows current to flow slowly through the precharge resistor until the inverter capacitors are charged. The main contactor is then closed and the precharge relay is opened. Canbus communication with the inverter and throttle verification are required for this step to complete.

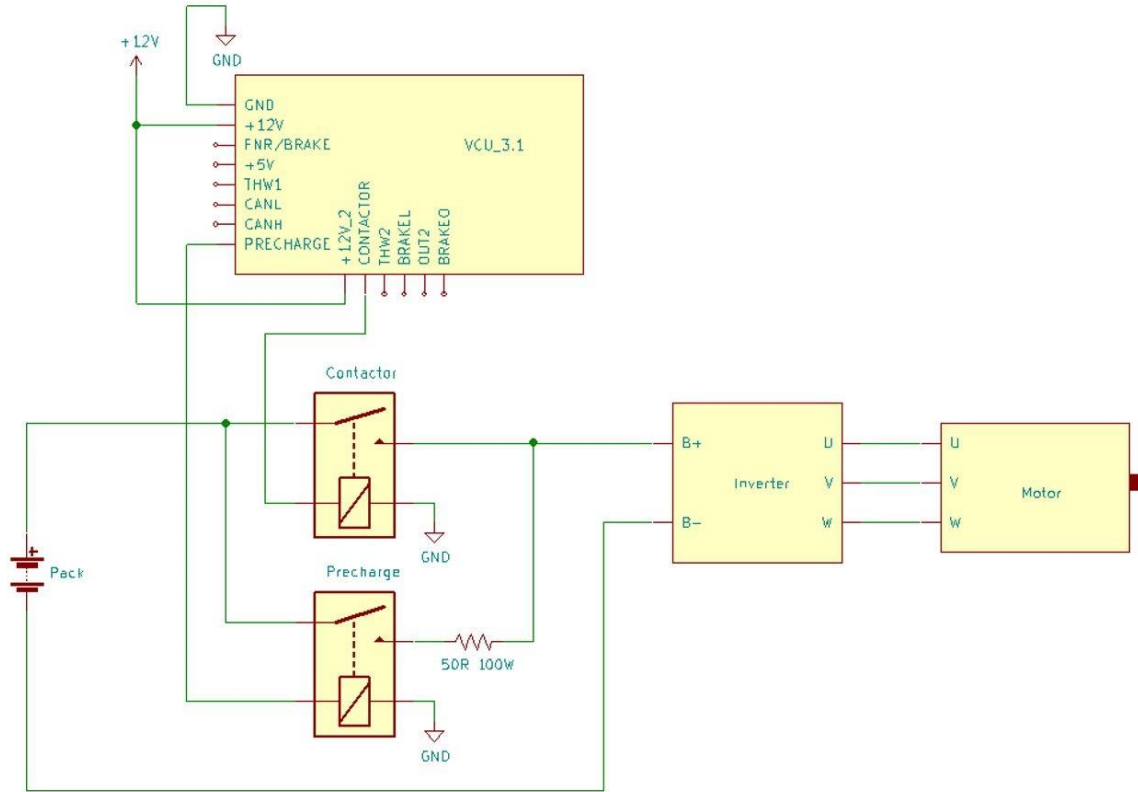

Figure 6 – PRECHARGE and CONTACTOR Wiring

FNR/BRAKE

The **FNR/BRAKE** input can be used as a direction switch (forward/reverse or forward/neutral/reverse), or used as a brake pressure transducer input.

There are two variants of the 3.1 VCU hardware. If the VCU was purchased after late May 2021, then an FNR rework applies, and the BRAKE option is not available (serial VU00297 and after). The following diagram shows suggested wiring.

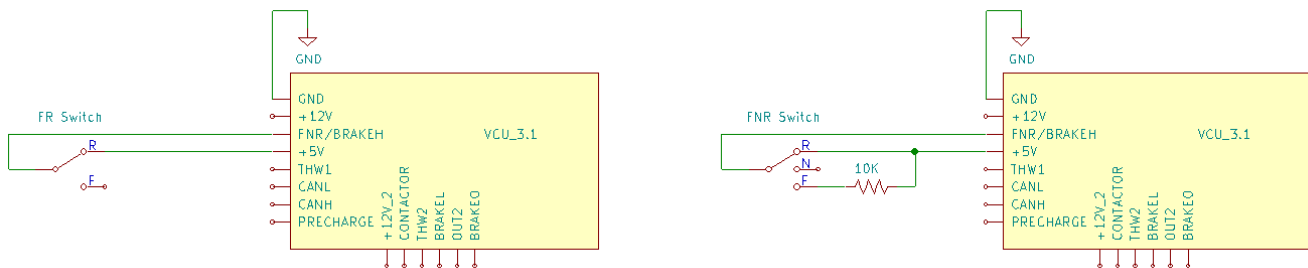

Figure 7 – Direction Switch Wiring after May 2021 - FR enabled on left, FNR enabled on right

Non-reworked versions of the VCU can support either FR/FNR or the BRAKE input. See below for how to wire up these versions (serial VU00296 and prior). Note that an additional external resistor is required for FR / FNR operation.

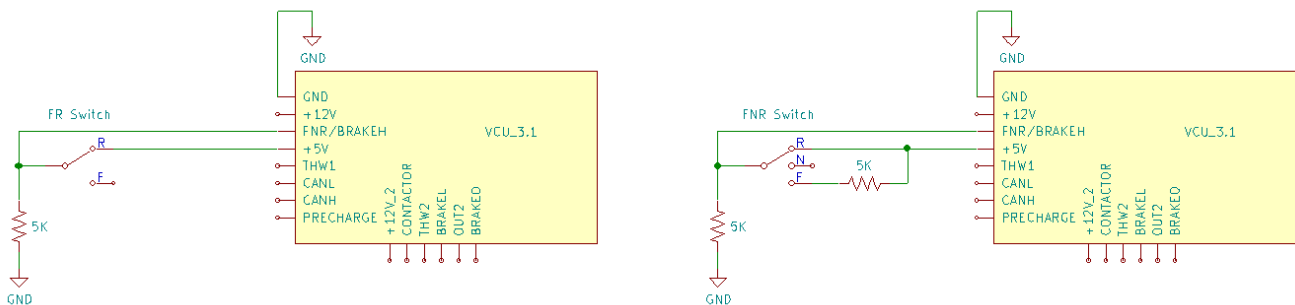

Figure 8 – Direction Switch Wiring (without the "FNR rework")

In order to configure a Forward / Reverse switch, use the command **enable fr**. Once configured, if the **FNR/BRAKE** input is $\leq 4.0V$ then the requested direction is forward, and if the input is $> 4.0V$, the requested direction is reverse.

To configure a Forward / Neutral / Reverse switch, use the command **enable fnr**. Once configured, if the **FNR/BRAKE** input is $\leq 1.5V$ then the requested direction is neutral, else if the input is $\leq 4.0V$ then the requested direction is forward, else the requested direction is reverse.

If a Brake Transducer is used, then the **FNR/BRAKE** input should be connected to the wiper output of the brake transducer. In this case, the VCU will request a variable amount of reverse torque depending on brake pedal pressure. See the *VCU Configuration* section for more information.

BRAKEL (Brake Light Input) and BRAKEO (Brake Light Output)

BRAKEL is a brake light input. This input connects directly to the brake light switch: it expects the input to be high impedance (or disconnected) when there is no brake and connected to +12V when the brake is applied. When the brake is on, the throttle input is ignored and the VCU requests a configurable amount of braking regeneration.

The VCU can control the brake light using the **BRAKEO** output. The VCU enables this output if it is requesting sufficient negative torque (regeneration). The **BRAKEO** output is an “open collector to ground” output that can operate a 200ma relay which can provide +12V to the vehicle brake light circuit.

The Brake Light Input and Brake Light Output features can be used independently or together, as desired. However, if both features are used together, an additional relay is required.¹

See suggested wiring diagrams below. The diagram on the left shows the wiring for just the BRAKEL connection (with the BRAKEO connection unused). The diagram on the right shows an example of using both the BRAKEL and BRAKEO connections. The third example, just using BRAKEO, is not shown. (But if desired, would be the right side diagram with only a single relay.)

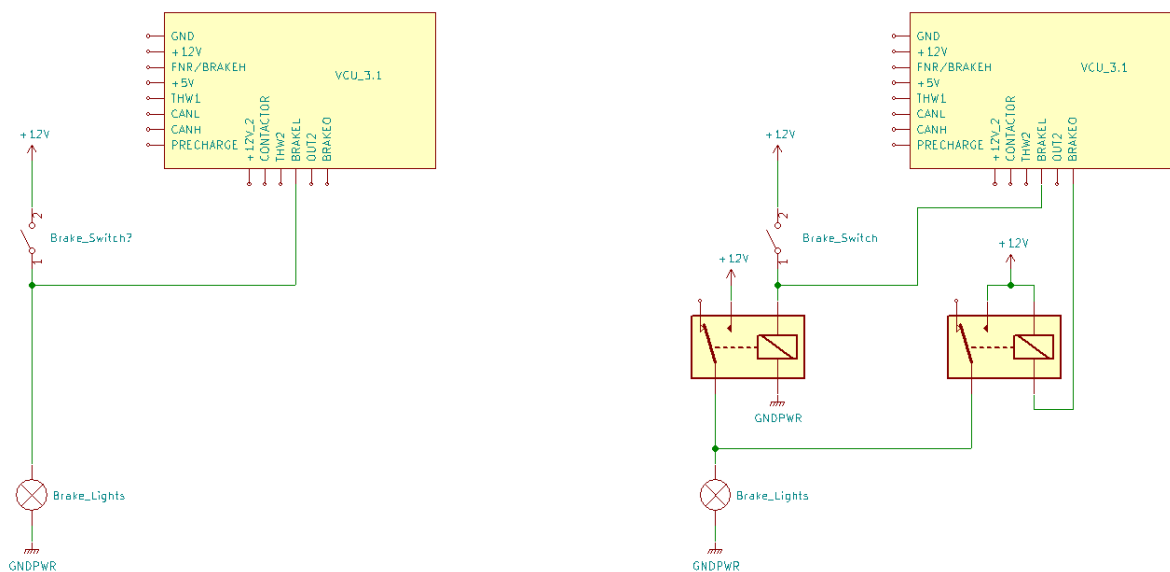

Figure 9 – BRAKE Light Input and BRAKE Light Output Wiring

OUT2

Beginning with VCU firmware release 3.1.8, the **OUT2** output is active (or “on”) when the FNR switch is in “Reverse”, and is inactive (“off”) otherwise. This allows the OUT2 output to control a backup light circuit.

Note that OUT2 is an “open collector to ground” output: it is high impedance (or no connection) when it is “off”, and it is connected to GND when “on.” This can be used to complete the circuit for a 12v automotive relay with a coil current of less than 200 ma. The relay contacts are wired to control the backup light circuit.

¹ The VCU needs to distinguish between “brake light is on because the user presses the brake pedal” and “brake light is on because the VCU itself is requesting negative torque.”

ZEO Leaf Inverter (EM61 Motor)

This section gives basic setup and wiring information on the first generation Leaf inverter, which was used in the Leaf 2010-2012 model years.

ZEO Inverter Connections

The following pinouts found in the Leaf manual (TMS.pdf) are used for 12v power and control. The Leaf canbus wiring uses colors opposite to that traditionally used by ThunderStruck/Dilithium products (from the Leaf inverter: blue is canbus HI, green is canbus LO).

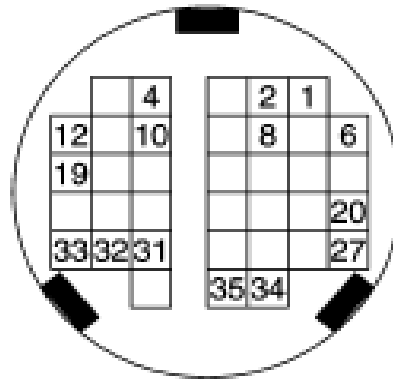

TRACTION MOTOR INVERTER

Pin numbers shown may not match numbers on mating connector – use the inverter pin layout shown above, using the tab locations for reference.

The table below lists the essential inverter 12v power and control connections. Connect 12V power through a ignition switch or a relay to pins 10 and 4. Always on power to pin 33. Pins 2 and 8 connect to 12v ground. The Leaf inverter requires about 1 Amp of 12V power for all the logic and IGBT drivers. Note the color difference between Leaf and VCU canbus wires. A 120 ohm termination resistor is required between CANH and CANL near the inverter connector. The inverter may shut down if a fault is detected. Disconnect all +12v power for 1 minute to clear faults.

Pin #	Connection	Pin #	Connection
2, 8	12v Ground	10, 4	+12v Key Switch
12	CANH (Leaf blue to VCU green)	19	CANL (Leaf green to VCU blue)
33	Always On 12v		

Resolver and temperature sensor wires must not be modified. Each pair is shielded which is grounded at the inverter. They are wired by Nissan as follows:

- 1,6 – Motor resolver S1-S3
- 20, 27 – Motor resolver S2-S4
- 31, 32 – Motor temperature-. Motor temperature+
- 34, 35 – Motor resolver R1-R2

ZEO Leaf Pack Connections

The power wires are not labeled on this inverter (see image below). With the inverter oriented normally, the upper terminal is positive. Remove the side cover to access the screws holding the wire lugs in place. Wires shown are for example only and do not represent correct wire gauge or routing.

Use of the factory harness between inverter and motor and for battery connections is recommended, because incorrect power or phase connections will disable or damage the system. Moisture protection and conductor shielding is an important consideration which the factory harness addresses.



AZE0 Leaf Inverter (EM57 Motor)

This section gives basic setup and wiring information on the Second Generation Leaf Inverter, applicable for model years 2013-2017.

AZE0 Leaf Inverter Connections

The following pinouts found in the Leaf manual (TMS.pdf) are used for 12v power and control. The Leaf canbus wiring uses colors opposite to that traditionally used by ThunderStruck/Dilithium products (from the Leaf inverter: blue is canbus HI, green is canbus LO).

Connector No.	F13	
Connector Name	TRACTION MOTOR INVERTER	
Connector Color	BLACK	



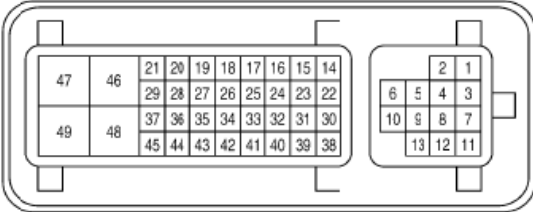

Terminal No.	Color of Wire	Signal Name
1	-	-
2	-	-
3	-	-
4	-	-
5	-	-
6	-	-
7	-	-
8	-	-
9	-	-
10	-	-
11	-	-
12	-	-
13	-	-
14	L	EV SYSTEM CAN-H
15	G	EV SYSTEM CAN-L
16	-	-
17	P	REZ_S2
18	L	REZ_S4
19	R	REZ_R1
20	B	REZ_S1

Terminal No.	Color of Wire	Signal Name
21	W	REZ_S3
22	-	-
23	-	-
24	-	-
25	-	-
26	-	-
27	G	REZ_R2
28	-	-
29	-	-
30	-	-
31	-	-
32	-	-
33	-	-
34	-	-
35	-	-
36	-	-
37	-	-
38	-	-
39	-	-
40	-	-
41	-	-
42	LG	IGN_SW
43	-	-
44	O	TMGND
45	Y	TM
46	G	VB1
47	B	VBGND1
48	G	VB2
49	B	VBGND2

The table below lists the essential inverter 12v power and control connections. Connect 12V power through a ignition switch or a relay to pin 42. Always on power to 46 and 48. Ping 47 and 49 connect to 12v ground. The Leaf inverter requires about 1 Amp of 12V power for all the logic and IGBT drivers. Note the color difference between Leaf and VCU canbus wires. A 120 ohm termination resistor is required between CANH and CANL near the inverter connector. The inverter may shut down if a fault is detected. Disconnect all +12v power to clear faults.

Pin #	Connection	Pin #	Connection
47,49	12v Ground	42	+12v Key Switch
14	CANH (Leaf blue to VCU green)	46,48	Always On +12v
15	CANL (Leaf green to VCU blue)		

Resolver and temperature sensor wires must not be modified. Each pair is shielded which is grounded at the inverter. They are wired by Nissan as follows:

- 17,18: Motor resolver S2-S4
- 19,27: Motor resolver R1-R2
- 20,21: Motor resolver S1-S3
- 44,45: Motor temperature-, Motor temperature+

AZE0 and ZE1 Leaf Pack Connections

Note that the pack polarity is not labeled on the inverter. With the Charger to inverter connection port open, the right-hand terminal is the pack B+, as in the following image (year 2013 and newer).

Thunderstruck provides a 3-D printed plastic cover for the high voltage terminals on these inverters. This is used to insulate and protect the exposed terminals, but requires a sealant to protect the inverter internals from exposure to moisture.



ZE1 Leaf Inverter (EM57 Motor)

This section gives basic setup and wiring information for the third generation Leaf inverter, with the designation ZE1. The ZE1 inverter is common for 2018+ model year Nissan Leafs, with 110 and 160 kw power versions and the EM57 motor.

Nissan Leaf ZE1 Inverter Connections

The pinout diagram shown is viewed from the wire side of the inverter connector when attached. The installed vertical orientation of the connector is not as shown in the diagram. Use the bottom notch shown for reference.

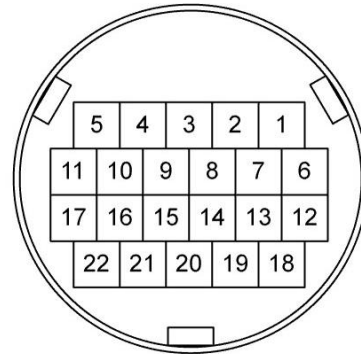

The table below lists the essential inverter 12v power and control connections. Connect 12V power through a ignition switch or a relay to pin 18. Always on power connects to pins 1 and 6. Pins 4 and 10 connect to 12v ground. The Leaf inverter requires about 1 Amp of 12V power for all the logic and IGBT drivers. Note the color difference between Leaf and VCU canbus wires. A 120 ohm termination resistor is required between CANH and CANL near the inverter connector. . The inverter may shut down if a fault is detected. Disconnect all +12v power to clear faults.

Pin #	Connection	Pin #	Connection
4,10	12v Ground	18	+12v Key Switch
5	CANH (Leaf blue to VCU green)	1, 6	Always On +12v
11	CANL (Leaf green to VCU blue)		

Resolver and temperature sensor wires must not be modified. Each pair is shielded which is grounded at the inverter. They are wired by Nissan as follows:

3, 9: Motor resolver S2-S4

22, 16: Motor resolver R1-R2

19, 14: Motor resolver S1-S3

7, 20: Motor temperature+, Motor temperature-

See the AZE0 section above for inverter to battery pack connection polarity.

Operation Information for all Leaf Inverters

Cooling

Cooling is essential for the inverter and motor. Coolant should flow from the inverter to the motor to keep inverter temperatures lower. Coolant pump operation should be continuous, and radiator fan operation is optional, depending on system thermal requirements.

The image to the right depicts a 1985 Toyota pickup conversion which is a test vehicle at ThunderStruck Motors.

Numbers indicate coolant flow sequence. The hose labeled number 5 connects to the coolant reservoir; 1 and 7 connect to the radiator; 6 is the coolant pump.

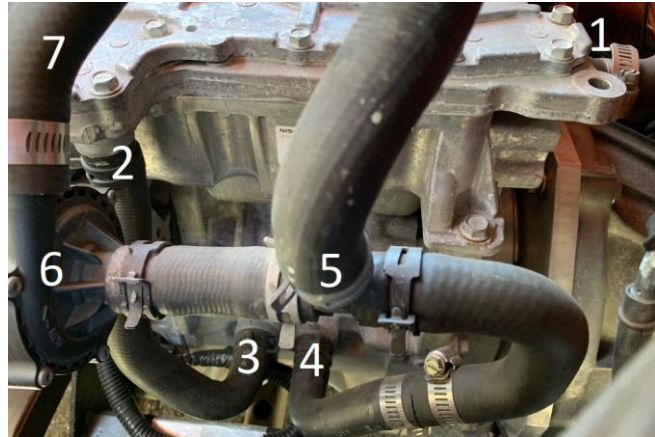

The coolant reservoir should not be under pressure and is placed at the highest point in the system so trapped air can easily escape.

Leaf Inverter Operation

Consider the following for initial operation after wiring is completed.

1. The reduction drive parking pawl must be disengaged before operation. Remove the pawl motor assembly and rotate the splined shaft counterclockwise to do this (expect a strong detent).
2. Apply power to the “Always ON +12v” inverter terminal.
3. Apply power to the “Keyswitch +12v” inverter terminal and “+12v” VCU terminal for startup.
4. The Inverter expects to receive CAN messages from the VCU within 2 seconds of startup.
5. Tests show that reliable inverter operation requires pack voltages above 200 volts, so a fully charged pack of at least 250 volts is recommended.

Common Issues

The Leaf inverter enters a failsafe mode after sensing internal errors or missing canbus instructions. If this happens, correct any known issues, then disconnect all 12v power to the inverter and start again after waiting about one minute.

All model year Leaf inverters use blue wire for canbus HI and green for canbus LO. These are connected to opposite color wires (e.g. blue to green) in the VCU canbus. The OEM wiring harness connects the inverter to the motor resolver. Keep the original wiring harness if possible. The motor will not operate if the resolver connector is missing, damaged, or wired incorrectly.

The inverter and motor are factory matched, and will not function if from different vehicles. All Leaf inverters restrict RPM in the reverse (motor shaft clockwise) direction, and the VCU does not alter this limit.

UQM and UQM Coda Inverter Setup

This section provides information on configuring the UQM Inverter using a software utility. There are two supported UQM variations: UQM and UQM Coda, and both are configured identically.

Inverter wiring is detailed in the *UQM High Voltage Wiring* and *UQM Low Voltage Connections* paragraphs below.

Inverter Configuration

See the UQM manuals for additional details and settings if provided with your system.

If the UQM inverter was purchased from ThunderStruck Motors, we will set up the inverter for operation with the VCU and bench test the system. To access to the the *UQM Motor Controller* software, contact ThunderStruck Motors.

To configure the UQM inverter, open the *UQM Motor Controller* software on a Windows computer. On the Control Tab, enable CANbus Control. On the CANbus Settings Tab, set the following:

- 11 bit identifiers
- Little Endian
- Drive Mode = Torque
- Baud Rate = 500kbps
- Transmit CAN messages = enabled
- Message “Set Enables” (see Figure 13)
- Timeout Period = 250 msec
- Counter = Ignore Counter
- Require Heartbeat Command = NOT enabled

For the Message “Set Enables” above, the VCU firmware requires only one message from the inverter, which is the “Watchdog Status” message. All other messages *may* be enabled but are not necessary for normal operation. A “Universal Feedback” message is included by default, and is required by the VCU for RPM, temperature and voltage information.

UQM Inverter Configuration Examples

The following *UQM Motor Controller* software screenshots show parameter configuration windows for a UQM Coda installation. Different Inverters require specific settings based on the manufacturer’s specifications. Changes beyond parameter values specified should be made only if implications are completely understood by the user.

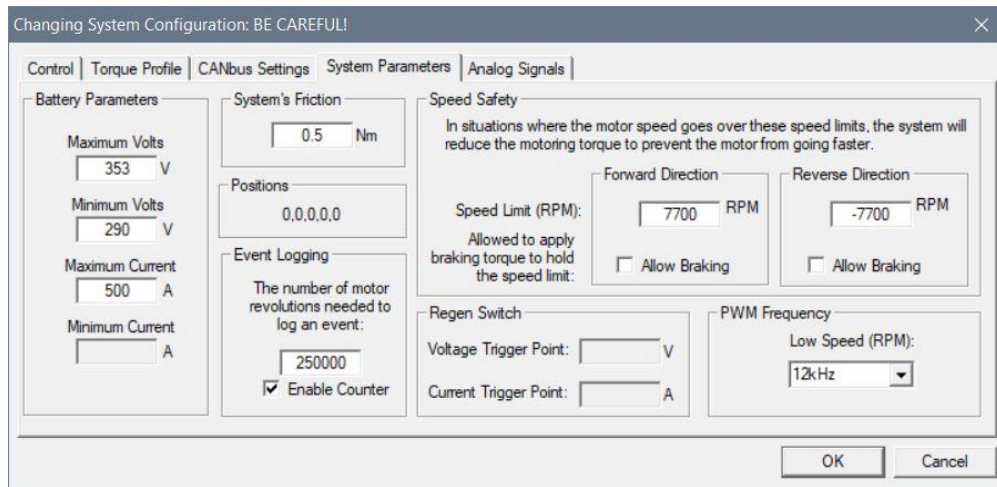

Figure 10 – UQM Configuration – System Parameters Tab

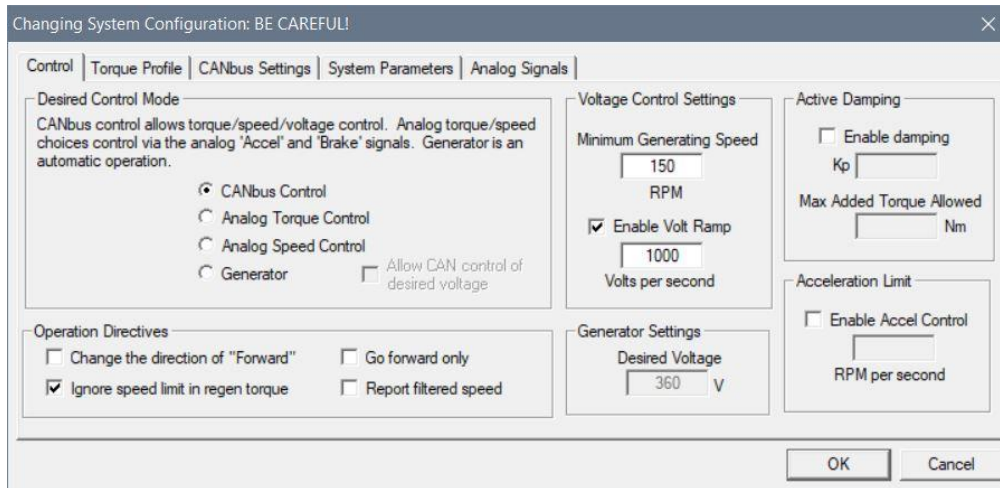

Figure 11 – UQM Configuration – Control Tab

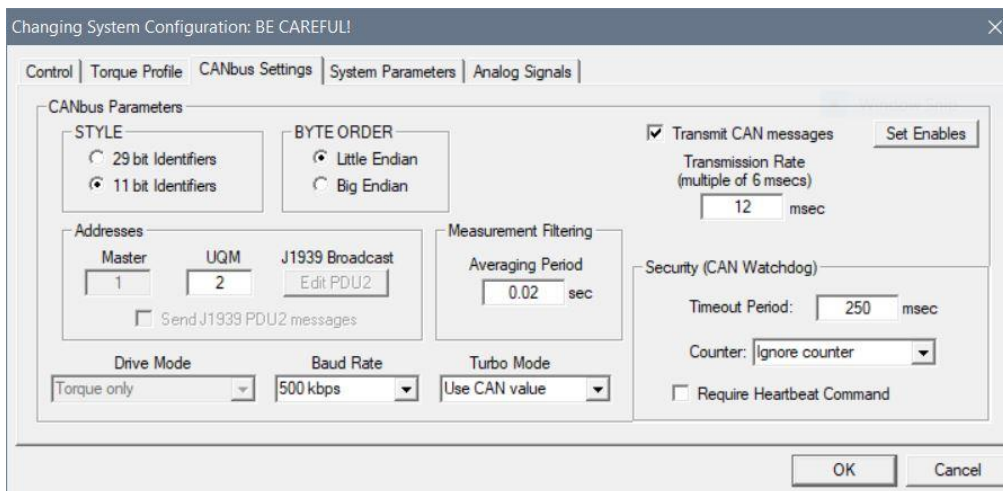

Figure 12 – UQM Configuration – Canbus Settings Tab

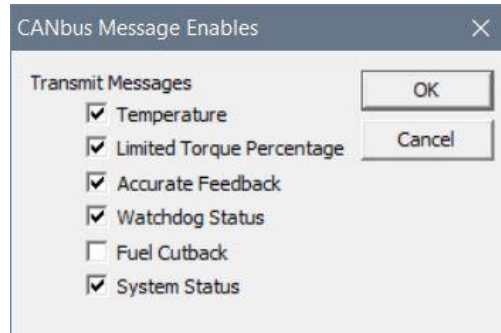
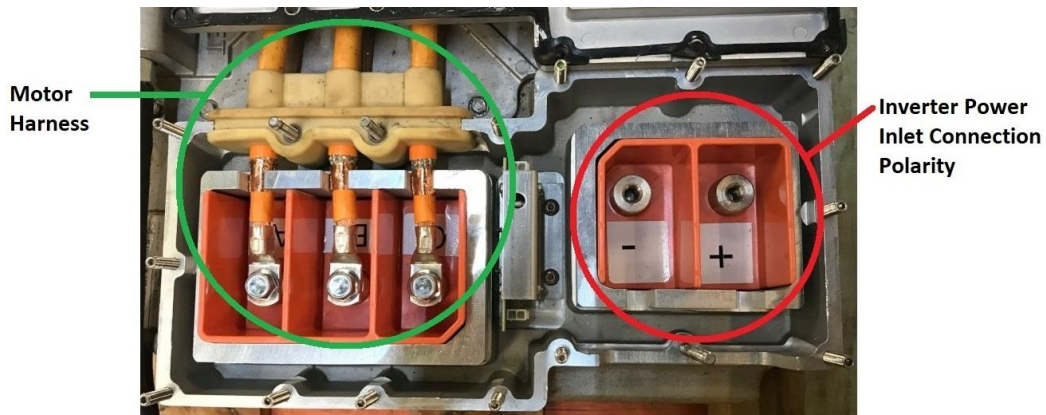

Figure 13 – UQM Configuration – Canbus Settings Tab - Enables

UQM High Voltage Wiring

Refer to the specific UQM manual if available for the motor/inverter set being used for your project. Typically, the motor harness will be provided with your equipment, which enforces polarity.

Polarity of the traction pack connection is very important. In our experience UQM manuals may not always show this clearly. The figure below shows typical polarity.



UQM Low Voltage Connections

Low voltage connections use the UQM Inverter Deutsch connector. A computer connects to the UQM via a DE-9 connector. In the image below, Deutsch pin 1 is lower right and 12 is upper right. The DE-9 pin 1 is upper right and 9 is lower left. See page 19 of the UQM user manual for complete Deutsch pinouts. In the table below, Deutsch = DT, DSub DE-9 = DE.

Deutsch Pin	Connected To	Deutsch Pin	Connected To
DT 1	12v positive	DT 7	DE 2
DT 2, 3, 11	No Connection (NC)	DT 8	DE 3
DT 4	CANH (VCU green)	DT 9	DE 5
DT 5	CANL (VCU blue)	DT 10	12v positive (NC for UQM Coda)
DT 6	CAN common (NC)	DT 12	12v negative

Notes:

- 1) 120 ohm resistor should be installed between DT 4 and 5
- 2) CAN HI and LO are connected to the VCU canbus
- 3) DT 1 and DT 10 can connect to the 12v keyswitch bus

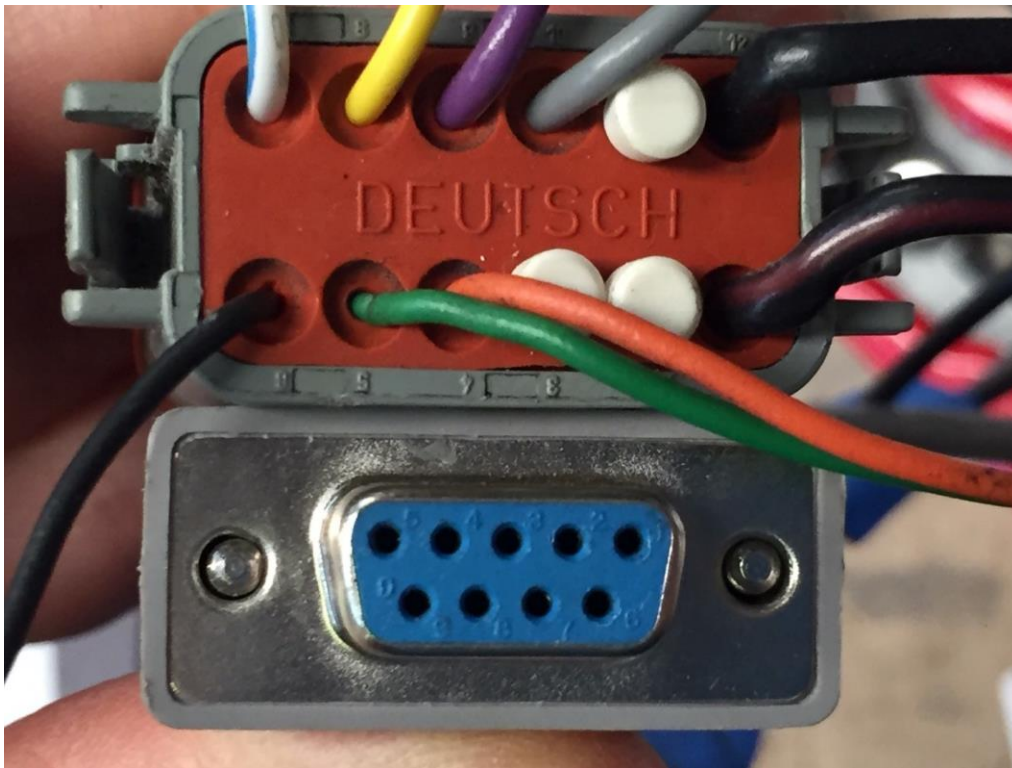

UQM Inverter/Motor Cooling

Cooling is required for inverter and motor operation. Please see *Operation Information for all Leaf Inverters* above, for an applicable cooling circuit example.

VCU Configuration

Serial Port Drivers

The VCU uses a specific USB to serial port cable for configuration, firmware upgrade, and debugging. Before using the serial port, a terminal application and host drivers must be installed, such as PuTTY or Coolterm. See the document *Serial Port Utilities* for instructions on how to install this software. This document is located in the VCU page tab *Manuals & Downloads* on the Thunderstruck-ev.com website.

Once installed, the serial port is connected and power is applied to the VCU. The following banner message will be displayed on the serial port console:

```
*****
*           Vehicle Control Unit v3.2.7           *
*   Thunderstruck Motors / Dilithium Design   *
*****
vcu>
```

At this point, the VCU can be configured. Configuration is stored in non-volatile memory and retained across power cycles. See *Command Line Interface*, below, for details on commands and syntax.

Note that if the command **trace verbose** was entered prior to shutdown, then diagnostics performed automatically at startup will be shown after the startup banner.

ThunderStruck Motors recommends against using the text interface while driving the project vehicle. The user interface is intended for bench testing or while the vehicle is on a lift. Safety precautions must be taken to protect personnel and equipment during testing.

Throttle

The VCU supports throttles that output between 0 to 5v. The default throttle type (**thtype**) in the VCU is a single wiper **hall** throttle. This selection will also work with a resistive throttle. The throttle working range must be configured in the VCU (using **set thw1off** and **set thw1max**). To determine the correct values see the throttle datasheet or use the **measure** command, described below. If the throttle gives a reading that is outside of the working range, it will fail its diagnostics.

The VCU also supports a dual output throttle, which may be enabled by the command **set thtype dhall**. Dual output throttles provide redundancy: the output from the **THW1** wiper is used as the primary throttle input and the **THW2** output provides a failsafe check. In operation, the VCU requires that the two wiper outputs track together. In this case, the throttle outputs are constantly checked to make sure they track together. If they do not, then the throttle is disabled.

If the throttle type is **hall**, the second throttle wiper input, **THW2**, is not used and is available for other functions. See below, *Power Takeoff*.

Map

In operation, the throttle input is converted to a number between 0% (no throttle) and 100% (full throttle). Percent throttle is then converted to requested torque. By default, the mapping from throttle percent to torque is linear: 20% throttle requests 20% of the maximum configured torque (using the command **set maxtorque**).

The throttle map allows the throttle response to be tuned. For example, the user may want 25% throttle to only request 10% of the torque in order to “soften” the initial throttle response.

The VCU can define up to three throttle ranges (between 0% to 100%): range1, range2, and range3. Range1 starts at zero and ends at **r1top**, range2 (if configured) starts at **r1top** and continues to **r2top**, and range3 (if configured) starts at **r2top** and continues to 100. These ranges are set by the commands **set r1top** and **set r2top**.

Once a range is defined, within each range there is a weight or “scale” from 0.0 to 5.0, which determines throttle responsiveness within the range. The command **set r1scale** sets the “weighting factor” for range1 and the command **set r2scale** sets the “weighting factor” for range2. It is not necessary to set the weighting factor for range3 as the VCU computes it automatically.

By default, there is one range: **r1top** is 100, and **r1scale** is 1.00.

Brake

A brake input is optionally supported that can be used to control regenerative braking. The brake type is set using the command **set brtype** and can be set to one of: **none**, **hall**, or **switch**.

When a brake input is configured, the total amount of braking regeneration is set using **set brakeregen**.

If the **brtype** is set to **switch**, then if the brake is applied (the **BRAKEL** input is 12V), then the throttle input is ignored and the VCU will request the configured amount of braking regen.

If the **brtype** is set to **hall**, then the **FNR/BRAKE** input is used to apply a variable amount of regen (up to a maximum configured **brakeregen** value), depending on the braking pressure. As with the throttle, the working range of the a hall BRAKE input must be configured (using **set broff** and **set brmax**).

If the **brtype** is set to **hall**, the FNR input must be disabled, and Forward is the only option.

```
vcu> disable fnr
vcu> set brtype hall
```

Motor / Inverter

This section describes the parameters used to control the motor and inverter.

- **inverter** sets the inverter type. It must be one of **leaf**, **leafgen1**, **uqm** or **coda**.
- **prechgminv** is a parameter which sets the minimum precharge voltage that must be attained before the main contactor is closed.

The following parameters determine throttle / torque response:

- **maxtorque** sets the maximum torque in Neuton Meters (Nm).
- **maxrpm** sets the RPM limit.
- **maxrpmtorque** sets the torque limit at maximum RPM
- **torquekneerpm** sets the start of RPM based torque limiting
- **jerklim** sets a limit on rapid changes in torque requests

For the UQM inverter, the **maxtorque** and **maxrpm** parameters are required and set absolute bounds for motor operation. For the Leaf, the **maxtorque** parameter is required. The Leaf motor controller has internal RPM limiting and so **maxrpm** need not be configured, unless the torque knee feature is used.

For the Coda inverter, **maxtorque** is required and is limited to 300 Nm. This parameter must be within the correct range before changing inverter types.

The torque knee feature uses the parameters **maxrpm**, **maxrpmtorque** and **torquekneerpm**. This feature is used to taper the torque as the motor RPM increases. Tapering is linear: the effect starts at the **torquekneerpm** (where the torque could be as high as **maxtorque** under full throttle) and it is limited to **maxrpmtorque** when **maxrpm** is reached. To disable the torque knee feature, set **torquekneerpm** to zero.

For example, suppose the following settings have been entered:

```
vcu> set inverter leaf
vcu> set maxtorque 280
vcu> set maxrpm 10000
vcu> set maxrpmtorque 5
vcu> set torquekneerpm 8000
```

Under full throttle, the VCU will initially request a torque value of 280 Nm from the controller. When the motor RPM reaches 8000 RPM, the requested torque starts to decrease from 280 Nm and will reach a limit of 5 Nm when the RPM reaches 10000 RPM.

For regenerative braking, the following parameters are configured:

- **regenmax** sets the pack voltage limit. Regeneration is limited when the pack is full.
- **idleregen** sets the amount of regeneration when the throttle is at 0%. If not used, set to zero.
- **brakeregen** sets the amount of regeneration when braking. If not used, set to zero.

These parameters set maximum values. In operation the actual amount of regen requested from the motor controller depends on several factors, including: throttle mapping, throttle position, motor RPM and pack voltage.

The following parameters are used for automatic transmission operation. This feature is only available if a Direction Switch is NOT being used.

- **idletorque** sets the maximum torque used when idle
- **idlerpm** sets the RPM target for idle

The following parameter is used for a “power takeoff” function. This feature is only available with the UQM motor.

- **maxrpm2** sets the RPM limit for power takeoff function.

Maximum torque limits vary significantly between inverters. Research is needed to determine this value for a specific system. Estimated torque limits are shown below for each of the configurable inverters.

Inverter	Torque Limit
Nissan Leaf ZE0 and AZE0 (80 kW, 2010-2017)	280 Nm
Nissan Leaf ZE1 (110 kW, 2018)	320 Nm
Nissan Leaf ZE1 (160 kW, 2019+)	339 Nm
UQM Coda (100 kW)	300 Nm
UQM (example: PP220)	700 Nm

DC/DC Converter

VCU firmware no longer supports canbus control of Chevy Volt or Delphi DC/DC converters. Best practices suggest the motor inverter and DC/DC converter should require independent canbus control. Tests have shown that control of devices from different manufacturers on the same canbus network may lead to interference. DC/DC converters capable of operating with a 12v enable circuit may be safely used in conjunction with the VCU.

An independent controller is required for canbus controlled DC/DC converters, for instance the MCU or Canbus Translator, which can be found on the Thunderstruck website.

Diagnostics

The VCU user interface provides a means for setting configurable parameters and performing various diagnostic functions. Note that when the VCU passes large text strings to the user interface, it requires data space which can cause delays or interruptions in communication with the motor inverter.

ThunderStruck Motors recommends against using the text interface while driving the project vehicle. The user interface is intended for bench testing or while the vehicle is on a lift. Safety precautions must be taken to protect personnel and equipment during testing.

Additional diagnostic and wiring information is available online on the VCU Manuals & Downloads tab. See the *VCU Troubleshooting Guide* and *VCU Output and Input Wiring Diagrams* documents.

measure

The **measure** command can be used to measure the voltage present on the **THW1**, **THW2**, **FNR/BRAKE** and **BRAKEL** inputs. When entered, the command repeatedly measures and prints the analog value of these inputs for up to 30 seconds. The measurement can be stopped by pressing any key.

The following is an example of a FNR measurement:

```
vcu> me fnr
fnr= 4.92V (R)
fnr= 4.92V (R)
```

The **measure** command can be used to characterize the hall throttle and hall brake inputs at zero and full throttle. For example, the **me thw1** measurements can be used to determine the correct **thw1off** and **thw1max** configuration parameters.

Trace

The trace command is processor intensive, and is intended for system diagnosis when components are being bench tested, or when the vehicle is on a lift. ***The vehicle should not be in motion while tracing.***

trace can

CAN message tracing prints out the CAN ID, message source, and raw contents. CAN message tracing is enabled using the command **trace can**.

trace verbose

trace verbose is a modifier used to trigger additional data during standard traces, and also triggers information during startup useful for trouble diagnosis.

trace uc

trace uc is used to show decoded messages sent from the VCU to the inverter. If enabled, the trace will show values used within the VCU for preparing messages to the inverter.

As an example, see the **trace uc** command from a Nissan Leaf inverter below. This shows the information sent from the VCU to the inverter. The output includes timestamp, FNR and Brake status, motor RPM, % Throttle, Throttle Deadstop position in % at the stated RPM, Torque request %, Brakel (BLI) Input status, BrakeO (BLO) output status, Torque Request in Nm.

```
vcu> trace uc
00:02:11.4 Ff 153.0rpm 86% 390.0V 2% %torque=0 BLI OFF, BLO OFF, 205.8Nm
00:02:11.5 Ff 212.0rpm 96% 388.0V 3% %torque=0 BLI OFF, BLO OFF, 254.8Nm
```

Startup Diagnostics

At power-up (and whenever throttle parameters are reconfigured), a throttle diagnostic is performed by the VCU. If an error is detected, it will be saved for display in the **show** report, and the throttle will be rendered non-operational. If trace verbose has been enabled, then errors will show during the startup process and when error states change.

Example show report after startup success using VCU v3.2.7 and later firmware:

```
vcu> show
  contactor: enabled
  throttle  : ok
  inverter  : running
  thw1      : 0.81V (0%)
  thw2      : 1.60V
  brakel    : off
  fnr       : 2.53V (F)
  packv     : 128.0V
  uptime    : 0 hour(s), 0 minute(s), 35 second(s)
vcu>
```

Valid “contactor” states are: warmup, precharge, or enabled.

- The `warmup` state is a transitory state just after powerup.
- The `precharge` means either that the precharge timer has not expired or, if `prechgminv` has been programmed, that the pack voltage is lower than `prechgminv`.
- The `enabled` state means the contactor is enabled.

Valid “throttle” states are: `warmup`, `test`, `failed`, `waiting for N`, `not idle`, `ok`.

- The `warmup` state is a transitory state just after powerup.
- The `test` state is a transitory state where the throttle wiper values are being range checked (and if dual wipers are configured, that they are within acceptable relationship with each other).
- The `failed` state means that the self test has failed.
- The `waiting for N` state is waiting for the FNR switch to go to N; applies if the `nwait` option is enabled.
- The `not idle` state waits for the throttle to go idle.
- The `ok` state is the normal operating state.

Valid “inverter” states are: `running` and `not running`. `Running` indicates that CAN messages are being received from the inverter.

Additional diagnostic messages can be displayed using the command `trace verbose`. For example, if `trace verbose` were enabled and precharge is not succeeding, the following message might be displayed:

```
vcu> Inverter Voltage too low (0.0V) ... not enabled !
```

For additional information about the startup procedure, see the *Operation* section.

Operation

Startup

At startup, the **PRECHARGE** output is enabled and throttle diagnostics are performed. A 2.5 second timer is started. At the end of 2.5 seconds the VCU verifies that the throttle is at idle, and if **prechgminv** is configured, verifies that the inverter voltage is higher than the precharge minimum voltage. If these tests pass, the **PRECHARGE** output is disabled, the **CONTACTOR** output is enabled, and the VCU enters an operational state. If the throttle is not at idle or if the inverter voltage is not high enough, the VCU will register an error and continually retry. If **trace verbose** has been set, then errors will print to the interface screen.

If the throttle diagnostics fail, verify throttle configuration and **THW1** and **THW2** measurement readings. If the precharge diagnostic fails, then verify the correct operation of the precharge and contactor relays.

During operation, the VCU continues to verify that the throttle readings stay within the configured ranges. If they do not, then the VCU will register an error retry diagnostics three times. If they continue to fail, the VCU will stop sending torque requests to the inverter. In this state, the LED will blink in the Failed state and it will be necessary to power cycle the VCU to retry.

If the **nwait** feature is enabled, the VCU will wait until neutral has been engaged once after startup before permitting torque requests to the inverter. This is an optional VCU safety feature which is standard in most OEM systems.

Direction Switch

If a “forward / reverse” or “forward / neutral / reverse” switch is configured:

- When the requested direction is Neutral, a torque of 0 Nm will be requested, regardless of throttle position. While driving, it is always possible to switch into Neutral.
- Requests to switch to the opposite direction of the motor rotation are generally prevented while in motion. If the motor is turning at >120 RPM, then the VCU will ignore a request to switch to Reverse and will switch to Neutral instead. Similarly, if the motor is turning at < -120 RPM, then the VCU will ignore a request to switch to Forward and will switch to Neutral instead.
- It is possible to switch from Forward to Neutral and back again if the motor is moving in a forward direction.
- If **nwait** is enabled, activate the neutral switch at least once after startup before trying to move the vehicle.

Throttle

Percent throttle is converted to percent maximum torque based on motor RPM, requested direction, throttle map, and **deadspot** (described below). The maximum torque that can be requested is the configured value **maxtorque**.

Braking Regen

The brake input, if active, takes precedence over the throttle. If the brake type is set to **switch**, and brake is applied, then the configured value of **brakeregen** is requested from the controller. If the brake type is set to **hall**, then depending on how hard the pedal is depressed and the motor RPM, a percentage of **brakeregen** is requested from the inverter.

Idle Regen / Throttle Braking

If **idleregen** is configured, the full amount of idleregen torque will be experienced if the motor is turning at greater than 1600 RPM and the throttle is completely released.

The throttle position of zero torque is configurable using the command **set deadspot**, which is specified in percentage. If the motor is turning at greater than 1600 RPM, then a deadspot of 20 means that at 20% throttle the VCU will request zero torque; larger than 20% throttle will request positive torque (up to **maxtorque** at full throttle), less than 20% throttle will request negative torque, and 0% throttle will request the full amount of **idleregen** torque. This feature allows the driver to brake the EV largely by using the throttle only.

In order to smooth the response, the amount of regen requested depends on throttle position and speed when the motor is turning at less than 1600 RPM.

The VCU supports a regen voltage limit (using **set regenvmax**). The VCU monitors inverter voltage and limits the amount of regen requested as the inverter approaches or exceeds this limit.

Operation – Leaf (all versions)

The VCU recomputes torque command parameters every 100ms. The VCU sends torque requests via the to the Leaf inverter (using the 0x1d4 message) every 10ms. Torque requests may be traced using the command **trace uc**.

The VCU receives messages from the Leaf inverter 0x55a message which may be traced using the command **trace can**.

See the *Diagnostics* section for additional information and safety considerations while using the **trace** command.

RPM limits are enforced by the Leaf inverter firmware. However, the VCU has a configurable feature providing a soft RPM limit enforced by torque (see “**torquekneerpm**”).

Operation – UQM

The VCU sends canbus messages to the UQM every 125ms. If the UQM inverter canbus message indicates there is a *watchdog error*, the VCU will recover by sending the UQM Heartbeat command, as recommended in the UQM canbus manual.

The VCU operates the inverter in torque mode up to the RPM limit configured using **set maxrpm**. The VCU throttle mapping is used to determine percent throttle, which translates to the requested torque. Note that the requested torque is a function of throttle position, RPM, and the parameters used for the torque knee feature, which tapers the maximum available torque based on RPM (see “**torquekneerpm**”).

The VCU supports a second RPM limit for a “power takeoff” application. In this application, the operation of the throttle remains the same, but an alternate maximum RPM (**maxrpm2**) may be configured. Enabling the second limit is done by the **THW2** input and is only available if the thtype is set to **hall** (not **dhall**). If **THW2** is > 4v, then the second RPM limit is chosen.

Operation – UQM Coda

The Coda system is a modified UQM drivetrain, so its operation is very similar to the UQM. However, for the Coda inverter, forward and regen torque are limited to 300 Nm. The Universal Command is updated every 125ms, but sent to the inverter every 10ms. The Heartbeat command is sent periodically rather than in response to an error, so the Watchdog Status message will not be seen.

LED

The single green LED provides basic status. There are four blink patterns:

- **Failed** is shown as a fast blink. This means either that the VCU diagnostics failed, or the Inverter is either posting an error or is not communicating properly.
- **Warmup** is shown as a slow blink.
- **Bootloading** is shown as a very fast (1/8 second) blink, while new firmware is being uploaded.
- **Running** is a solid ON (not blinking).

Firmware Upgrade

A firmware upgrade may be recommended if a specific feature or issue correction is required. See the document *Serial Port Utilities* document for instructions on how to perform a firmware upgrade. This document is located in the VCU page tab *Manuals & Downloads* on the Thunderstruck-ev.com website.

Serial Interface

The VCU provides a text interface for user configuration, troubleshooting and firmware upgrades. A specific serial to USB communication cable is provided by Thunderstruck Motors for this purpose. Text interface options and installation procedures are described in the Serial Port Utilities document mentioned above.

NOTE: The text interface is intended for bench testing or while the vehicle is on a lift. Using the text interface while driving can interfere with normal vehicle operation and is not recommended.

Startup Banner

When the VCU is powered up, the user interface will display the following (version number varies):

```
*****
*           Vehicle Control Unit v3.2.7           *
*   Thunderstruck Motors / Dilithium Design   *
*****
```

Status lines below the banner indicate the command **trace verbose** has been previously enabled, in which case after safety checks complete, the system will be activated and the following message will display:

```
vcu> Precharge Complete
```

help

The **help** command prints out command help.

```
vcu> help
  SHow [<>|Version|Config]
    <>      - status
    version - firmware version
    config  - configuration
  SET  [<>|INVERTER|PRECHGMINV|REGENVMAX
    |THTYPE|THW1OFF|THW1MAX|THW2OFF|THW2MAX
    |R1TOP|R2TOP|R1SCALE|R2SCALE
    |BRTYPE|BROFF|BRMAXS
    |MAXTORQUE|MAXRPM|MAXRPMTORQUE|TORQUEKNEERPM
    |MAXRPM2|JERKLIM
    |IDLEREGEN|BRAKEREGEN|DEADSPOT
    |IDLETORQUE|IDLERPM
  ENABLE [CANTERM|FR|FNR|NWAIT]
    canterm - enable can termination resistor
    fr      - enable forward/reverse switch
    fnr     - enable forward/neutral/reverse switch
    nwait   - enable wait for N before starting
  DISABLE [CANTERM|FR|FNR|NWAIT]
  TRace [CAN|UC|VERBOSE]
    - enable trace
```

```

TRace- [CAN|UC|VERBOSE]
        - disable trace
TRace OFF      - disable all tracing
MEasure [<>|THW1|THW2|FR|FNR|BRAKE|BRAKEL]
  <>          - 'measure' help
  thw1       - measure throttle wiper1 A/D
  thw2       - measure throttle wiper2 A/D
  fr         - measures fr switch
  fnr        - measures fnr switch
  brake      - measure brake wiper A/D
  brakel     - measures brake light input
RESET CONFIG  - resets configuration to defaults
UPGRADE       - performs a firmware upgrade

```

In some cases, either a full version or an abbreviated version of a command (or command parameter) can be used. This is shown in the “help” report with the use of uppercase and lowercase letters. For example, the abbreviation for **show** is **sh**, and the abbreviation for **show config** is **sh c**.

show <>

If **show** is entered without parameters, system status will be displayed.

```

vcu> show
  contactor: enabled
  throttle  : ok
  inverter  : running
  thw1      : 0.75V (0%)
  thw2      : 0.38V (0%)
  brakel    : off
  fnr       : 2.51V (F)
  packv     : 375.0V
  CAN Errs  : txerrcnt= 0, rxerrcnt= 0
             : tx abort= 0, tx larb= 0, tx msg err= 0
  uptime    : 0 hour(s), 0 minute(s), 12 second(s)

```

The **contactor** shows the contactor state, one of: warmup, precharge, or enabled.

- The **warmup** state is a transitory state just after powerup.
- The **precharge** means either that the precharge timer has not expired or, if **prechgminv** has been programmed, that the pack voltage is lower than **prechgminv**.
- The **enabled** state means the contactor is enabled.

The **throttle** shows the throttle state, one of: warmup, test, failed, waiting for N, not idle, ok.

- The **warmup** state is a transitory state just after powerup.
- The **test** state is a transitory state where the throttle wiper values are being range checked (and if dual wipers are configured, that they are within acceptable relationship with each other).
- The **failed** state means that the self test has failed.
- The **waiting for N** state is waiting for the FNR switch to go to N; applies if the **nwait** option is enabled.
- The **not idle** state waits for the throttle to go idle.
- The **ok** state is the normal waiting state.

The **inverter** shows the inverter state, one of: `running` and `not running`. `Running` indicates that CAN messages are being received from the inverter.

The **thw1** and **thw2** values are the THW1 and THW2 wiper values as read by the VCU.

The **brakel** value is the reading at the BRAKEL input (“off” = 0, “on” =12v).

The **brake** value is the brake wiper value (if configured).

The **fnr** value indicates which state (forward, neutral, reverse) is selected.

CAN Errs are displayed if trace verbose is enabled and lists canbus statistics.

The **uptime** is the VCU uptime since reset.

show version

The **show version** command displays firmware version number and build date.

```
vcu> sh version
  version   : v3.2.6 ; Feb 05 2025 17:33:20
```

show config

The **show config** command displays configuration parameters (varies per firmware version).

```
vcu> sh config
  THROTTLE
    thtype      : hall
    thwloff     : 0.10v
    thw1max     : 4.90v
  MAP
    rangel      : 0..100% throttle => 0..100% torque
    deadspot    : 30%
  BRAKE
    brtype      : switch
    brakeregen  : 100.0Nm
  MOTOR/INVERTER
    inverter    : leaf
    maxtorque   : 280.0Nm
    maxrpm      : 10000
    jerklm      : 500Nm/S
    idleregen   : 90.0Nm
    maxrpmtorque : 5.0Nm
    torquekneerpm : 5000
    prechgminv  : 310.0V
    regenvmx    : 410.0V
  OPTIONS
    FNR         : enabled (Forward/Neutral/Reverse switch)
    NWAIT       : enabled (wait for N before starting)
    canterm     : enabled (CAN termination resistor)
```

Configuration information is displayed in several sections, as follows:

show config THROTTLE

The **THROTTLE** section shows throttle parameters. The throttle type (**thtype**) can be **hall** or **dhall**.

thw1off is the low value of the THW1 wiper and **thw1max** is the high value of the THW1 wiper.

If the throttle type is **dhall**, then **thw2off** and **thw2max** must be configured, similar to the following.

```

THRATTLE
  thtype      : dhall
  thwloff     : 0.75v
  thw1max     : 4.59v
  thw2off     : 0.38v
  thw2max     : 2.29v

```

show config MAP

The **MAP** section defines the mapping between throttle percentage and requested torque percentage. The example above gives the default mapping. Only **range1** is defined, which maps 0..100% throttle to 0..100% torque. For more detailed examples, see *Throttle Map* below.

In addition to the throttle mapping, the **deadspot** parameter appears here. The **deadspot** is used for throttle controlled regeneration. When forward motor RPM is high enough, the value of **deadspot** is the percentage throttle that yields zero torque: a throttle value less than **deadspot** will request negative torque, and a throttle value greater than **deadspot** will request positive torque.

show config BRAKE

The **BRAKE** section shows the brake parameters. The brake type, **brtype**, can be **none**, **switch**, or **hall**. If the **brtype** is **none** or **switch**, no additional parameters are shown.

If **brtype** is **hall**, then the values of **broff** and **brmax** may be edited, which give the range of the brake pressure transducer. See the example below:

```

BRAKE
  brtype      : hall
  broff       : 0.00v
  brmax       : 5.00v

```

In operation the parameter **brakeregen** determines how much negative torque to apply when braking. If **brtype** is **switch**, then when the brake switch is applied, the full **brakeregen** torque is requested. If **brtype** is **hall**, then a percentage of **brakeregen** is requested, depending on brake wiper position, up to a maximum of **brakeregen** when the brake is fully depressed.

show config MOTOR/INVERTER

The **MOTOR/INVERTER** section shows motor parameters. The first parameter, **inverter**, shows the inverter type, with options **leaf**, **leafgen1**, **coda**, **uqm**. This parameter is initially set to **leaf**. The **inverter** parameter is unique in that it is the only parameter which is not changed by the command **reset config**. It must be explicitly set by the user to be changed.

The parameter **maxtorque** defines the maximum amount of torque requested from the inverter.

The value of **maxrpm** defines the highest RPM requested from the inverter. Note that the Leaf does not honor this parameter, as it has internal RPM limiting, however this parameter is used by the VCU for the torqueknee feature, described below.

The **jerklim** parameter affects throttle responsiveness, restricting rapid changes in torque requests. This can be useful when dealing with drivetrain backlash and high torque motor systems.

The UQM inverter supports **maxrpm2**, which is used for the power takeoff feature. See the UQM documentation for more details.

The UQM inverter also supports the parameters **idletorque** and **idlerpm**, which are used for automatic transmission applications. These values define the value of requested torque when no throttle is being applied.

The parameter **idleregen** is used for throttle braking. If 0 throttle is applied, up to idleregen negative torque is requested (the amount depends upon motor RPM, and is linear from 0 to 1600 RPM, where the maximum torque is applied if the motor is turning at 1600 RPM or greater). Throttle braking also uses the **deadspot** parameter. When forward motor RPM is high enough, the value of **deadspot** is the percentage throttle that yields zero torque: a throttle value less than **deadspot** will request negative torque, and a throttle value greater than **deadspot** will request positive torque.

The torque knee feature uses the parameters **maxrpm**, **maxrpmtorque** and **torquekneerpm**. This feature is used to taper the torque as the motor RPM increases. Tapering is linear: the effect starts at the **torquekneerpm** (where the torque could be as high as **maxtorque** under full throttle) and it is limited to **maxrpmtorque** when **maxrpm** is reached.

The parameters **prechgminv** and **regenmax** help maintain operations within whole pack voltage limits. **prechgminv** is a system startup minimum for the pack, and **regenmax** is a maximum not to be exceeded during regenerative braking.

show config **OPTIONS**

The **OPTIONS** section shows features which have been enabled. Features can be enabled or disabled in the user interface as follows:

```
vcu> enable fnr
vcu> disable fnr
```

FNR or **FR** will appear if the Forward/Neutral/Reverse (or Forward/Reverse) switch has been enabled.

NWAIT will appear if the neutral wait feature has been enabled.

canterm will appear if the internal canbus termination has been enabled.

set

This command is used to change configurable parameters. The following examples show using the set command to customize VCU configuration.

set <>

If **set** is entered with no parameters, **set help** will be displayed:

```
vcu> set
  SET [
      THTYPE|THW1OFF|THW1MAX|THW2OFF|THW2MAX
      thtype      - throttle type, one of [HALL|DHALL]
      thw1off     - THW1 reading with no throttle (from 'measure thw1')
      thw1max     - THW1 reading at max throttle (from 'measure thw1')
      thw2off     - THW2 reading with no throttle
```

```

    thw2max    - THW2 reading at max throttle
R1TOP|R2TOP|R1SCALE|R2SCALE
    r1top      - Range1 High Limit (0 <= r1top <= 100)
    r2top      - Range2 High Limit (r1top <= r2top <= 100)
    r1scale    - Range1 Scale factor (0.01 to 5.00)
    r2scale    - Range2 Scale factor (0.01 to 5.00)
BRTYPE|BROFF|BRMAX
    brtype     - [NONE|SWITCH|HALL]
    broff      - BRAKE reading with no brake (from 'measure brake')
    brmax      - BRAKE reading at max brake (from 'measure brake')
INVERTER|PRECHGMINV|REGENVMAX
    inverter   - [UQM|CODA|LEAF|LEAFGEN1]
    prechgminv- minimum inverter voltage to consider precharge complete
    regenvmx   - pack high voltage limit for regen
MAXTORQUE|MAXRPM|MAXRPMTORQUE|TORQUEKNEERPM
    maxtorque  - maximum available motor torque
    maxrpm     - maximum allowable motor rpm (default range)
    maxrpmtrq  - maximum torque at maximum rpm
    torquekneerpm - start of rpm based torque limiting
MAXRPM2|JERKLIM
    maxrpm2    - maximum allowable motor rpm (alternate range)
    jerklim    - jerk limit (NM/s)
IDLETORQUE|IDLERPM
    idletorque- torque at idle (used for automatic transmissions)
    idlerpm    - rpm at idle
IDLEREGEN|BRAKEREGEN|DEADSPOT
    idlereggen- (negative) torque to apply when no throttle
    brakeregen- (negative) torque to apply when braking
    deadspot   - idle regen throttle setpoint

```

```

]
vcu>

```

THROTTLE (thtype, thw1off, thw1max, thw2off, thw2max)

The command **set thtype** sets the throttle type. Valid values are **hall** and **dhall**.

The command **set thw1off** sets the expected throttle 1 wiper voltage when the throttle is off.

The command **set thw1max** sets the expected throttle 1 wiper voltage when the throttle is fully depressed.

The command **set thw2off** sets the expected throttle 2 wiper voltage when the throttle is off.

The command **set thw2max** sets the expected throttle 2 wiper voltage when the throttle is fully depressed.

Example configuration:

```

vcu> set thtype dhall
Reinitializing Throttle
vcu> FAULT: Throttle 2 A2D too low!
Throttle Failed; check connections and configuration ...
vcu> set thw1off .6
Reinitializing Throttle
vcu> Throttle self test complete
Throttle Enabled ...
vcu> set thw1max 4.4
Reinitializing Throttle
vcu> Throttle self test complete
Throttle Enabled ...
vcu> set thw2off .4
Reinitializing Throttle
vcu> Throttle self test complete

```

```
Throttle Enabled ...
vcu> set thw2max 2.0
Reinitializing Throttle
vcu> Throttle self test complete
Throttle Enabled ...
```

```
vcu> show config
THROTTLE
  thtype      : dhall
  thw1off     : 0.60v
  thw1max     : 4.40v
  thw2off     : 0.40v
  thw2max     : 2.00v
```

The VCU reinitializes and performs a self test whenever throttle parameters are edited.

THROTTLE MAP (r1top, r2top, r1scale, r2scale)

The following example defines two ranges. The first range is from 0 to 20% throttle, with a weighting factor of 2. The result will be that the first 20% of throttle will request 40% of the total torque. The effect of this will be that the throttle will be more responsive in the first 20% of throttle.

```
vcu> set r1top 20
vcu> set r1scale 2
vcu> set r2scale .8
vcu> show config

MAP
  range1      : 0.. 20% throttle => 0.. 40% torque
  range2      : 20..100% throttle => 40..100% torque
  -----
  r1top       : 20
  r1scale     : 2.00
  r2top       : 100
  r2scale     : 0.80
```

BRAKE (brtype, broff, brmax)

The command **set brtype** sets the brake type. It can be one of **none**, **switch**, or **hall**.

The command **set broff** sets the brake wiper voltage when the brake is off, valid only if **brtype** is **hall**.

The command **set brmax** sets the brake wiper voltage at maximum braking, valid only if **brtype** is **hall**.

As an example:

```
vcu> set brtype hall
vcu> set broff .4
vcu> set brmax 4.5
vcu> show config

BRAKE
  brtype      : hall
  broff       : 0.40v
  brmax       : 4.50v
vcu>
```

MOTOR/INVERTER (inverter, prechgminv, regenvmax)

The command **set inverter** sets the inverter type.

The command **set prechgminv** sets a minimum pack voltage before enabling the primary contactor.
The command **set regenvmax** sets a maximum pack voltage in which regen is allowed.

MOTOR/INVERTER (maxtorque, maxrpm, maxrpmtorque, torquekneerpm, jerklim)

The command **set maxtorque** sets the maximum torque that the VCU will request.

The command **set maxrpm** sets the maximum RPM that the VCU will request.

The command **set maxrpmtorque** sets the maximum torque that the VCU will request at maximum RPM.

The command **set torquekneerpm** sets the RPM at which RPM based torque limiting begins.

The command **set jerklim** affects throttle responsiveness, restricting rapid changes in torque requests.

For example:

```
vcu> set maxtorque 280
vcu> set maxrpm 6500
vcu> set torquekneerpm 4000
vcu> set maxrpmtorque 5
vcu> set jerklim 500
vcu> show config
MOTOR/INVERTER
  Inverter      : leaf
  maxtorque    : 280.0Nm
  maxrpm       : 6500
  jerklim      : 500Nm/S
  maxrpmtorque : 5.0Nm
  torquekneerpm: 4000
vcu>
```

MOTOR/INVERTER (maxrpm2)

The command **set maxrpm2** sets a secondary RPM limit used for the power takeoff function (UQM only).

MOTOR/INVERTER Automatic Transmission (idletorque, idlerpm)

The command **set idletorque** sets the amount of torque available at idle (UQM only).

The command **set idlerpm** sets the target RPM at idle (UQM only).

MOTOR/INVERTER Regen Configuration (idleregen, brakeregen, deadspot)

The command **set idleregen** sets the amount of braking regeneration to request when the throttle is at 0%.

The command **set brakeregen** sets the amount of braking regeneration to request when the (hall) brake is at 100% or when the (switch) brake input is ON.

The command **set deadspot** sets the throttle position of zero torque for “throttle braking”.

enable / disable

Can Termination

The command **enable canterm** enables the CAN termination resistor.

The command **disable canterm** disables the CAN termination resistor.

Neutral Wait

The command **enable nwait** prevents throttle activation before neutral is selected.

The command **disable nwait** allows throttle activation before neutral is selected.

Forward / Reverse Switch

The command **enable fr** enables the forward/reverse switch.

The command **disable fr** disables the forward/reverse switch.

Forward / Neutral / Reverse Switch

The command **enable fnr** enables the forward/neutral/reverse switch.

The command **disable fnr** disables the forward/neutral/reverse switch.

measure

The **measure** command is a diagnostic that shows the actual value read at the VCU inputs. This command may be used to verify Throttle, FNR and Brake wiring, and to characterize the working range of these devices. Measure can be used with **thw1**, **thw2**, **fr**, **fnr**, **brake**, or **brakel**. Once typed, it will repeatedly show the current input value for up to 30 seconds. It can be stopped by pressing any key.

Example:

```
vcu> measure thw1
vcu> thw1= 0.44V
thw1= 0.44V
```

measure <>

The **measure** command with no parameters shows measure help.

```
vcu> measure
This command repeatedly shows an analog input for 30 seconds.
Press any key to stop display.

The following values are expected
thw1   - 0v to 5v, depends on throttle specs
thw2   - 0v to 5v, depends on throttle specs
fr     - forward/reverse, >4.0v is reverse, else forward
fnr    - forward/neutral/reverse, >4.0 is reverse, > 1.5 is forward
              else neutral
brake  - 0v to 5v, depends on brake transducer specs
brakel - on or off
vcu>
```

trace

The **trace** command enables various forms of message or state tracing. These commands show a timestamp (uptime) and can be useful for logging or debugging. Trace configuration is stored in EEPROM and is present after reboot.

The trace command is processor intensive, and is intended for system diagnosis when components are being bench tested, or when the vehicle is on a lift. ***The vehicle should not be in motion while tracing.***

trace <>

the **TRace** command with no parameters shows active traces.

```
vcu> trace
no tracing enabled
```

trace uc, can, verbose

The following trace options are available, and can be run simultaneously (tr is a valid abbreviation).

UC - Lists the messages sent to the inverter

CAN – Lists the received canbus messages

VERBOSE – Allows debug information to show while the user interface is open.

For example, the following will start a canbus trace:

```
vcu> trace can
CAN tracing enabled
```

Adding a hyphen after the trace command disables the specified trace. When disabling traces, the command can be completed while trace messages are printing to the screen. The command **trace off** disables all traces at once.

```
vcu> trace- can
CAN tracng disabled
```

The **trace can** command displays canbus messages from the inverter, including the CAN ID and CAN message contents, in hexadecimal. An example of Nissan Leaf inverter data is shown below.

```
vcu> trace can
trace enabled: can
vcu>
00:00:11.8 <<NF 01da: c1 72 18 00 00 01 00 41
00:00:11.9 <<NT 055a: 13 3a 3b 00 5f 00 5b 08
```

Trace results are useful for troubleshooting system issues, and can be emailed to Thunderstruck for analysis. For best results, we recommend enabling all three trace results for support requests. When tracing is completed, tracing can be stopped by entering the **trace-** command before the name each active trace.

upgrade

The **upgrade** command is used to perform a firmware upgrade. This command will place the VCU into the serial bootloader mode, waiting for the load to begin. The VCU must be power cycled in order to leave this mode.

```
vcu> upgrade

***
***                Starting VCU Upgrade                ***
*** 1) Exit from the terminal application                ***
*** 2) Start the bootloader and download a new .hex file ***
*** 3) Restart the VCU                                  ***
```

If a firmware upgrade is recommended, Thunderstruck Motors will provide a new firmware file, which is processed using a bootloader app on a Windows computer.

For detailed upgrade instructions and access to the bootloader, see the *Serial Port Utilities* document in the VCU tab *Manuals & Downloads* on the Thunderstruck-ev.com website.

Warranty and Support

The product return policy is available on Thunderstruck’s website in the *About* section under *Return/Cancellation Policy*.

The Vehicle Control Unit is warrantied to be free from defects in components and workmanship under normal use and service for a period of 1 year.

When failing to perform as specified during the warranty period we will undertake to repair, or at our option, replace this product at no charge to its owner, provided the unit is returned undamaged and shipping prepaid, to Thunderstruck motors.

The product is intended for non-commercial use by hobbyists. The warranty does not apply to defects arising from miswiring, abuse or negligence, accidents, moisture exposure, opening the enclosure, or reverse engineering. Thunderstruck Motors and Dilithium Design shall not be responsible for any incidental or consequential damages.

Thunderstruck Motors and Dilithium Design reserve the right to make changes or improvements in design or manufacturing without assuming any obligation to change or improve products previously manufactured and/or sold.

For general support and warranty issues, contact
connect@thunderstruck-ev.com

For errors in this document, or comments about the product, contact
djmdilithium@gmail.com

Document History

Rev 3.0	Oct 2018	initial document
Rev 3.0.1	Nov 2018	added automatic transmission support
Rev 3.1	Dec 2018	update to 3.1 hardware
Rev 3.1.1	Nov 2019	added torqueknee feature
Rev 3.1.2	Jan 2020	minor edits
Rev 3.1.3	Nov 2020	added support for Gen1 Leaf and UQM Coda
Rev 3.1.4	Feb 2025	operation, UI and features updates – to FW v3.2.7