

# FOOT PEDAL ASSEMBLIES

## MODEL FP6

# CURTIS



## DESCRIPTION

*A durable foot pedal throttle assembly for use with Curtis PMC electronic motor speed controllers.*

## WARRANTY

2 years from date of delivery.

## Application

Curtis FP6 Foot pedal assembly is ideal for use in electric forklifts, golf carts, electric street vehicles and other vehicle types.

## Features

- *Rugged LM24 aluminium casing - ideal for tough environments such as material handling.*
- *The entire foot pedal rotates on its mounting base - for maximum installation flexibility.*
- *Cable exit points at rear - for easy installation.*
- *Dual return spring design ensures increased reliability*
- *5K potentiometer.*
- *Model FP6 includes two adjustable microswitches*
- *The foot pedal can be mounted on either side of the mounting base.*

## Specifications

### Curtis Model FP6:

- Maximum current for microswitches: 4A at 30V DC (Resistive load)
- 3 Wire 5K potentiometer (Curtis 98191)
- 7 Core cable. Length 1000mm
- Pedal shaft stainless steel SS 410

## Dimensions: mm (inches)

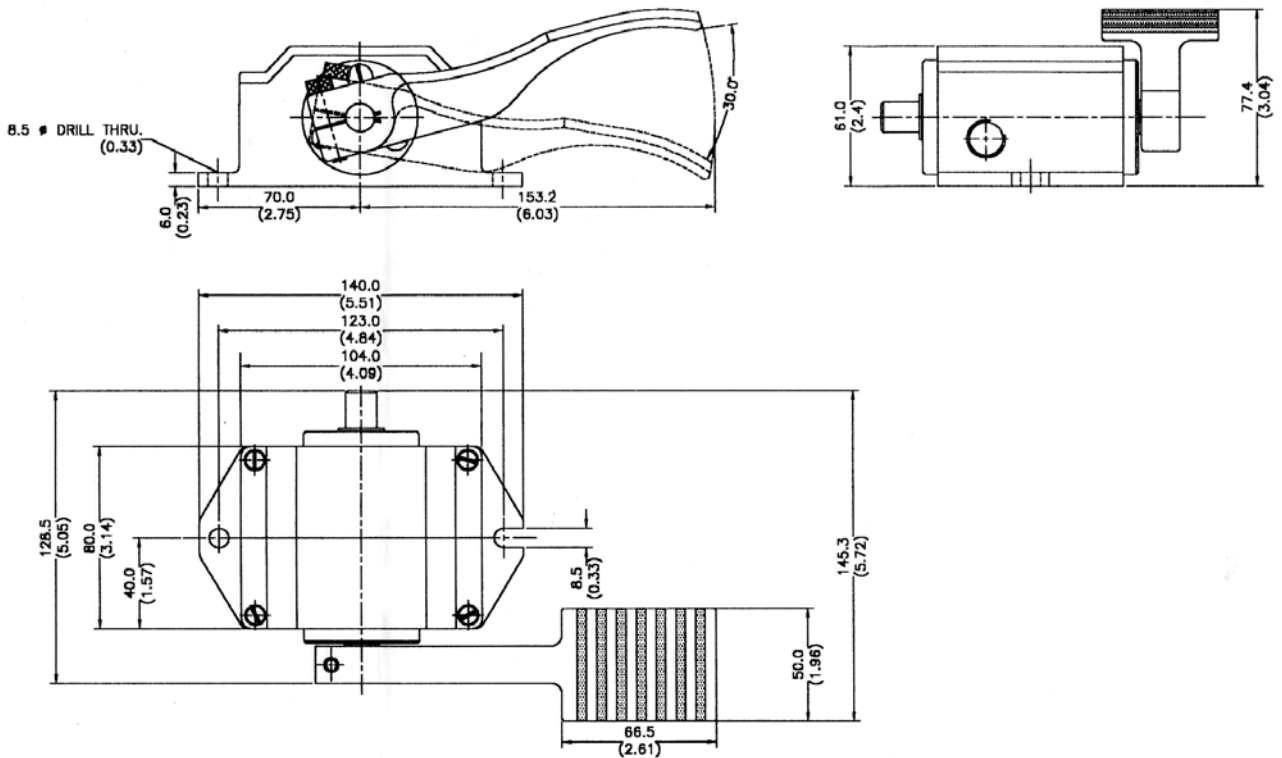

## Installation

Potentiometer – 5K

Wiring:

Wire Colour	Function
Black	Potentiometer low
White	Potentiometer wiper
Red	Potentiometer high
Green	Footswitch 1
Blue	
Yellow	Footswitch 2
Grey	

## Model Reference

FP6