



MODEL 1236/1238



FEATURES

Advanced Design and Functionality

- Major performance, operational and system advancements over DC.
- High frequency, silent operation from 0-300 Hz.
- 24V – 80V battery systems, 350-650 A RMS 2 minute current ratings.
- Powerful operating system allows parallel processing of vehicle control tasks, motor control tasks, and user configurable programmable logic.
- Advanced Pulse Width Modulation technology provides efficient use of battery voltage, low motor harmonics, low torque ripple, and minimized switching losses.
- Tunable to any AC motor. Fully programmable for optimal match to individual AC motor characteristics.
- Built-in battery state-of-charge algorithms and hour meter.
- Field-Programmable, with FLASH downloadable main operating code.

Superb Drive Control

- Field-oriented vector control, in conjunction with Curtis tuned algorithms, provide peak torque and optimal efficiency across the entire operating range.
- Extremely wide torque/speed range, including full regeneration capability.
- Internal closed-loop speed and torque control modes allow for optimized performance – without an additional control box.
- Peak performance mapping technology lets you tune the maximum performance envelope in both “driving and braking” to your specific application through the use of OEM programmable parameters.
- The Torque Control Mode offers unique features and provides seamless transitions and positive response under all conditions.
- Exclusive built-in pump control mode with superior response to hydraulic load changes.

DESCRIPTION

Advanced motor drive software provides smooth control over full speed and torque in all modes, including full regenerative braking, zero speed, and torque control.

APPLICATION

The Curtis 1236 and 1238 Motor Speed Controllers are designed for use in all types of electric vehicles including material handling, industrial, Golf, and light-on-road.

CURTIS INSTRUMENTS, INC.

200 KISCO AVENUE
MT. KISCO, NY 10549
USA
TEL (914) 666-2971
FAX (914) 666-2188

235 EAST AIRWAY BLVD.
LIVERMORE, CA 94551
USA
TEL (925) 961-1088
FAX (925) 961-1099

CURTIS INSTRUMENTS, (UK) LTD.

5 UPPER PRIORY STREET
NORTHAMPTON NN1 2PT
ENGLAND
TEL 44 (0) 1604-629755
FAX 44 (0) 1604-629876

CURTIS INSTRUMENTS INDIA PRIVATE LTD.

1199, GHOLE ROAD
PUNE 411004, INDIA
TEL 91 (0) 20-5531288
FAX 91 (0) 20-5539192

FEATURES *continued*

Unmatched Flexibility

- The unique Curtis Vehicle Control Language makes system design easier than ever for OEMs. Benefit from the many decades of Curtis experience in the EV industry by using the provided library of pre-defined functions, or quickly and simply write your own proprietary functions and algorithms to differentiate your systems from your competition.
- VCL empowers the controller to monitor and manage the entire vehicle system without additional hardware, to save cost and design time.
- Apply a wide range of I/O wherever you need them, for maximum distributed system control.
- CAN bus connection allows communication with other CAN bus enabled system components. Protocol meets CANopen standards, or is customizable through VCL.
- The same controller model can be used for either pump or traction applications due to the built-in software selectable pump control mode.
- Easily programmable through the Curtis 1311 handheld programmer and 1314 PC Programming Station.

Patents Pending

Robust Safety and Reliability

- Insulated Metal Substrate power base provides superior heat transfer for increased reliability.
- Fail-Safe power component design.
- Redundant hardware watchdog timers.
- Reverse polarity protection on battery connections.
- Short circuit protection on all output drivers.
- Thermal cutback, warning, and automatic shutdown provide protection to motor and controller.
- Rugged sealed housing and connectors meet IP65 environmental sealing standards for use in harsh environments.

Meets US and International Regulations

The Curtis Model 1236 and 1238 AC Motor Speed Controllers are designed to meet:

- EN 50081-1-2
- EN 61000-6-2
- EN 12895
- EN 1175
- IP65 Rated per IEC 529
- UL Recognized Component Status, UL 583

MODEL CHART

Model	Battery Voltage V	2 Min RMS Current Rating Arms (A)	2 Min RMS Power Rating (kVA)
1236-44XX	24-36	400	16.6
1236-45XX	24-36	500	20.9
1238-46XX	24-36	600	25.4
1236-53XX	36-48	350	19.7
1238-54XX	36-48	450	25.5
1238-56XX	36-48	650	36.3
1236-63XX	48-80	300	28.1
1238-65XX	48-80	550	51.3

SYSTEM ACCESSORIES



The Curtis Model 840 LCD Multifunction display contains 8 large, easy to read characters to provide display of battery discharge (BDI), hour meter and error messages. Built-in backlight is also available.



The Curtis Model 1311 Handheld Programmer is ideal for setting parameters and performing diagnostic functions.

Contact Curtis to obtain the VCL Vehicle Control Language compiler and development tools.

MODEL 1236/1238

CONNECTOR WIRING

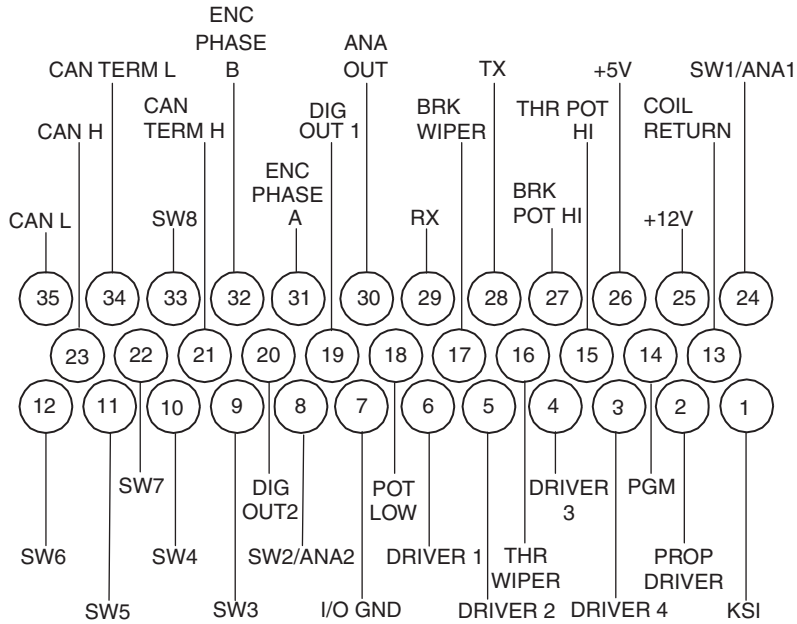

DIMENSIONS mm

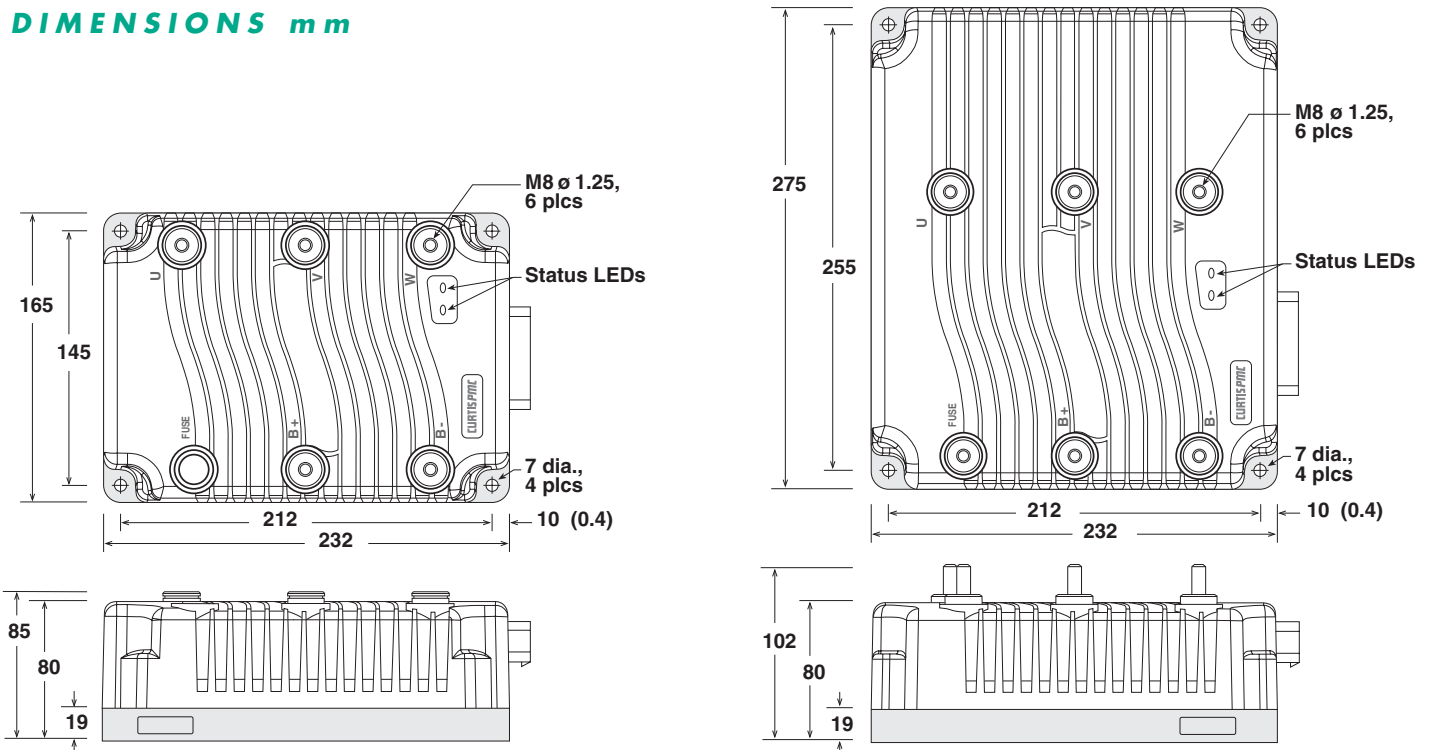

1236

1238

TYPICAL WIRING

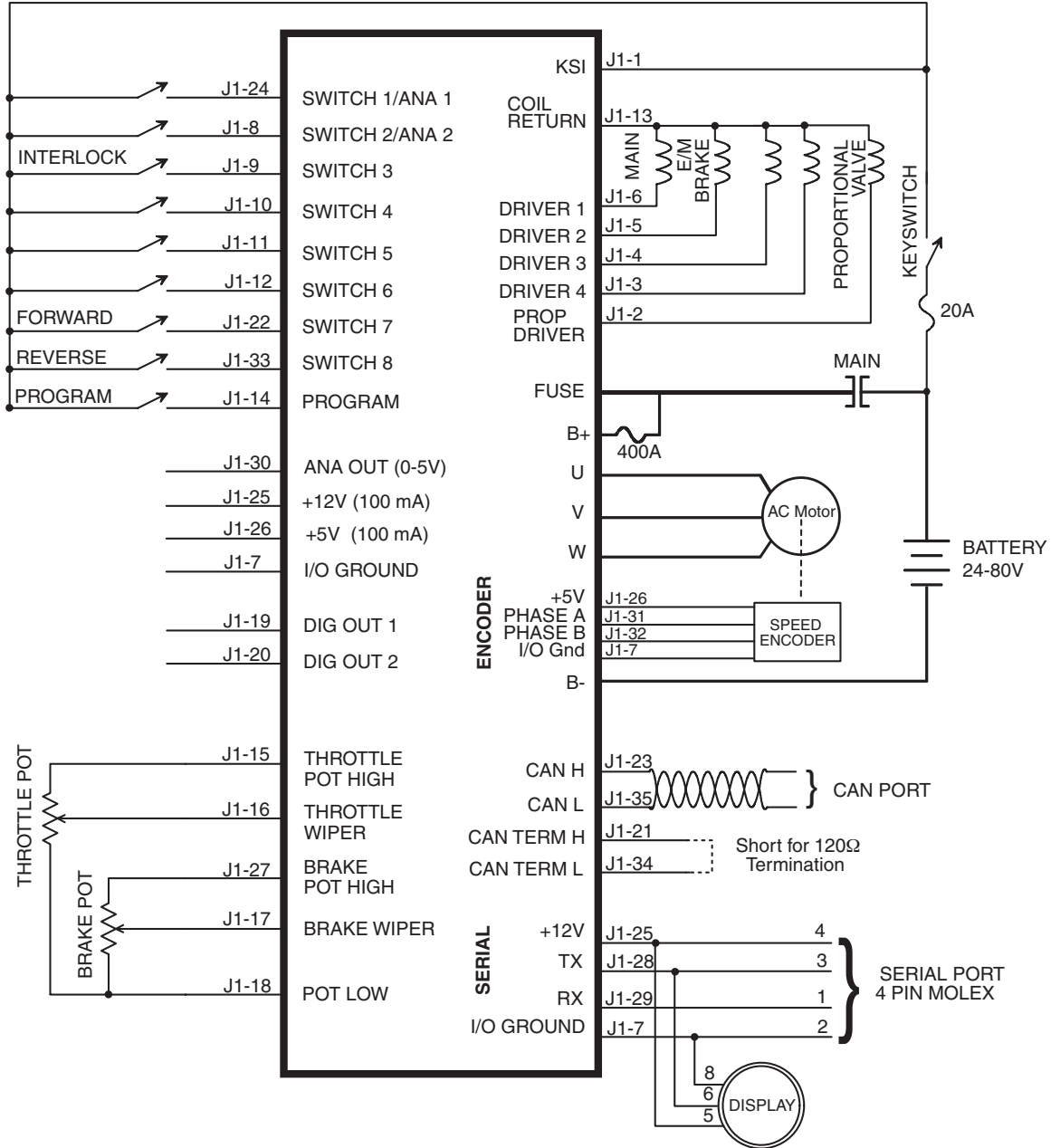

WARRANTY Two year limited warranty from time of delivery.



CURTIS

Specifications subject to change without notice

©2005 Curtis Instruments, Inc.

50095 REV E 7/05