



MILLIPAK 4QPM CONTROLLER MANUAL
FOR SYSTEM VERSION V1.01

Document History

Document History

Author		Reviewer		Version	Reason for Modification
Initials	Date	Initials	Date		
PB	06/03/01	-	-	0.01	Original.
DL / CEH	14/09/01			1.01	Document updated for V1.01 software

CONTENTS

Introduction

Safety

Installation

Mounting

MillipaK 4QPM Power Wiring

MillipaK Light Wiring example

Calibrator

Traction Drive Hours Counter

Calibrator Security Levels

Navigation

Adjustments

Status and Test Information

Configuration

System Configuration

System Voltage

System I/O Configuration

System / Motor Set-up

Contactor chopping

Accelerator Full /Zero Setting

Performance

Acceleration Delay

Deceleration Delay

Control Mode

Regen Braking

Braking Levels

Braking Entry and Exit

Footbraking

Creep Speed

Maximum Speed

Accelerator Characteristics

Features

Standard Controller Features

Power Steer

High Speed Switch and Anti-Tie Down

Seat Switch

Handbrake Switch

Cutback speeds

Traction Drive Hours Meter

Reverse Speed

Pump Soft Start

Reverse Buzzer

Line Contactor Drop out

Safety Features

Start Up Sequence

FS1 Recycle

Contents

- SRO (Static return to off)
- Belly Switch
- Anti-Rollback
- Anti-Rolloff
- Fail-safe
- Controller Protection Features
 - Temperature Monitoring
 - Safe Operating Area (SOA)
 - Under-voltage and over-voltage protection
- Commissioning Checklist
 - Personality Record
- Fault Finding
 - Fault Clearance
 - Fault Reporting Form
 - Software Version and Serial Number indication
- Specifications
 - Power Configurations
 - EMC standards
 - Socket B protection
 - Contactors drive ratings
 - Analogue Input Impedance
 - Digital Input Impedance
- EMC Guidelines
- Ordering Information

Introduction

The MillipaK 4QPM (Four Quadrant Permanent Magnet) range of controllers provides a new range of power frames for 24V-48V, 330A in small, highly efficient packages. This is achieved using a Sevcon patented power switching scheme and radical new construction techniques, which enable large powers to be incorporated into very small packages.

The MillipaK provides a completely sealed (IP66) unit containing both power and logic circuitry, as well as all suppression components and an optional integrated pump soft start/stop chopper.

MillipaK supports Sevcon's existing MOS90 calibrator for adjustment of vehicle performance characteristics. MillipaK is ideally suited to applications requiring a single traction controller, for example walkies, golf cars and basic ride-on trucks.

Controllers are FLASH microprocessor based enabling field re-programming for new features and have numerous user set-up options. The MillipaK uses high frequency (silent) MOSFET power switching technology, to control a 4Q power frame bridge. Armature current is monitored. Motor feedback should not be necessary. Controllers have been designed to satisfy the requirements of the relevant UL and EC standards.

Safety

The MillipaK controller contains a triple fail-safe system to give a high level of safety. If the diagnostic LED is not illuminated or flashes, the safety circuit may have tripped and the truck may not drive.

The controller must be used with a line contactor as indicated in the wiring diagrams. As blow-out magnets are fitted to contactors (except 24V) ensure that no magnetic particles can accumulate in the contact gaps and cause malfunction. Ensure that contactors are wired with the correct polarity to their power terminals as indicated by the + sign on the top molding.

The MillipaK controller may be used with suitable onboard chargers, as supplied by Sevcon.

There are several software features which are intended to prevent inadvertent or unexpected vehicle movement – SRO, Accelerator power up fault and sequence checking. Some of these features cannot be disabled and the appropriate signals must be supplied to the controller before drive will be allowed.

Installation

The small footprint of the MillipaK controller gives maximum flexibility to the user for mounting options. The following section gives details of certain criteria that should be considered when situating the controller on a vehicle.

Mounting

The MillipaK HP unit provides 4 x M6 clearance holes for mounting. The controller should be mounted onto a metal base plate, as large as possible to provide heat-sinking. The surface finish should be flat, clean and burr free and thermal compound should be applied to the controller base before fitting.

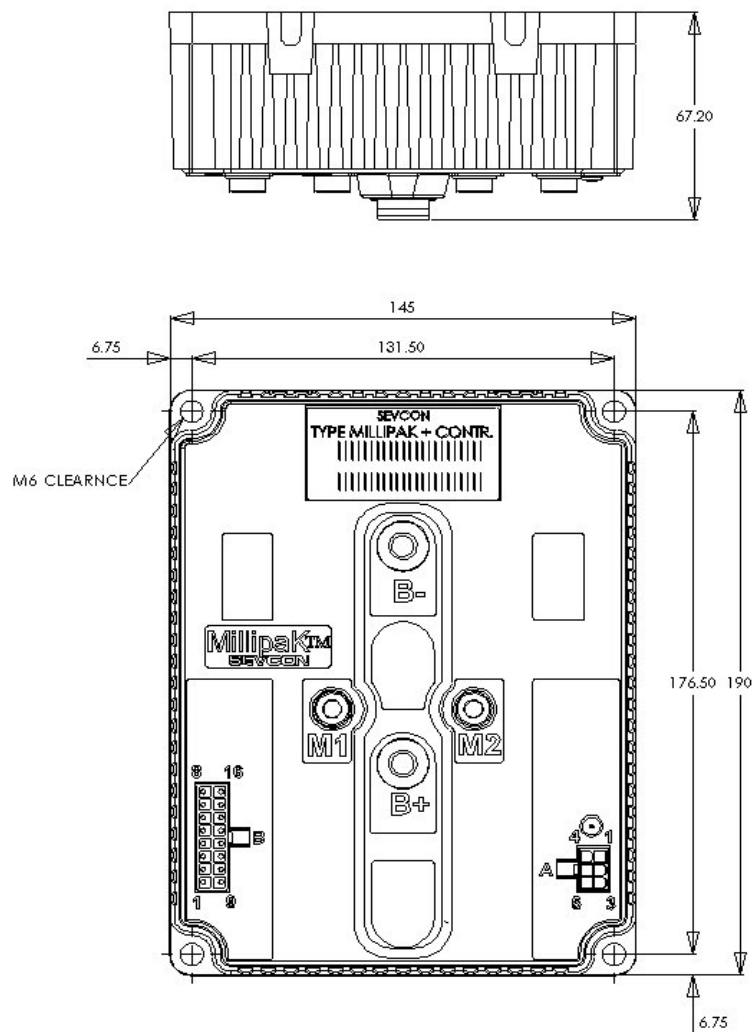

Figure 1: MillipaK HP Dimensions

Maximum terminal torque: M8 terminals – 10NM
 M6 terminals – 7NM

MillipaK 4QPM Power Wiring

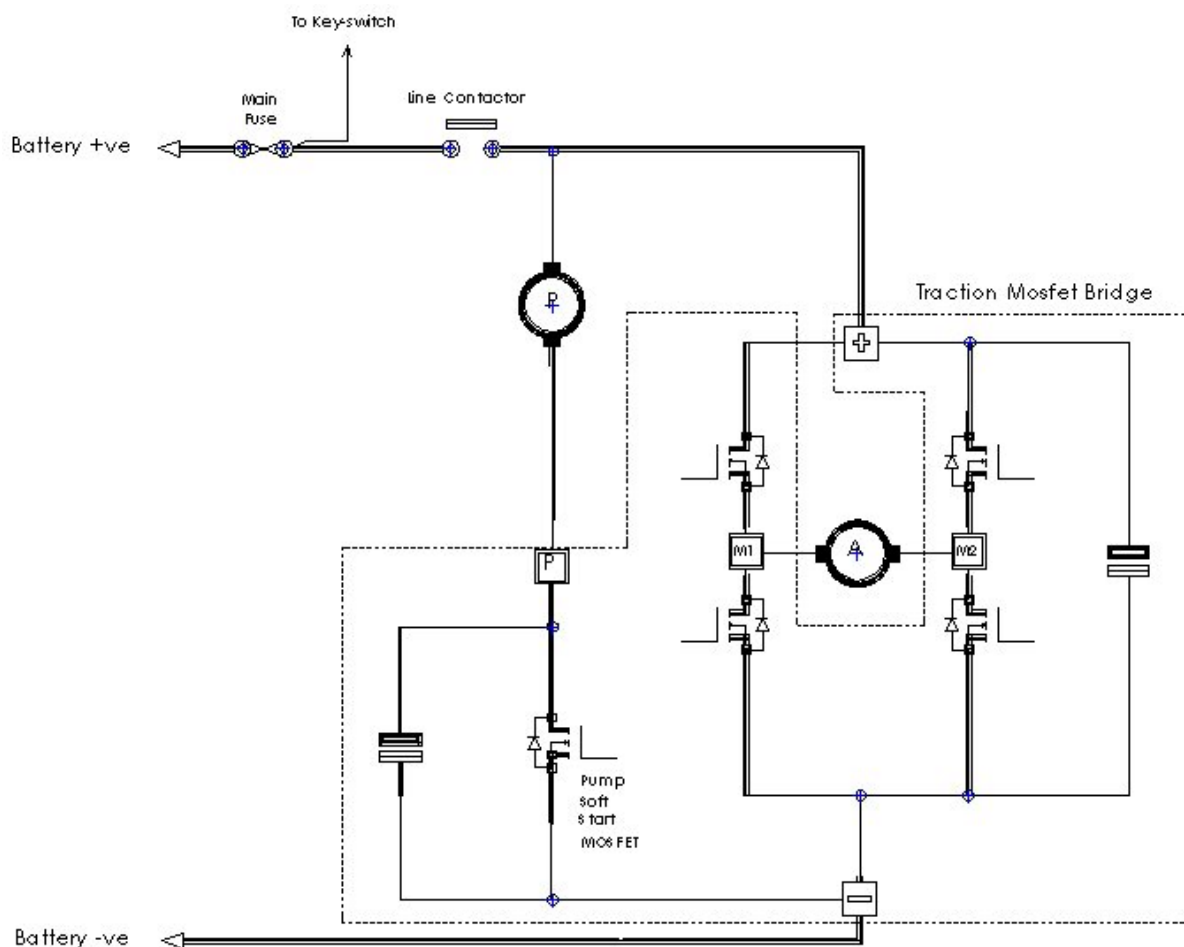
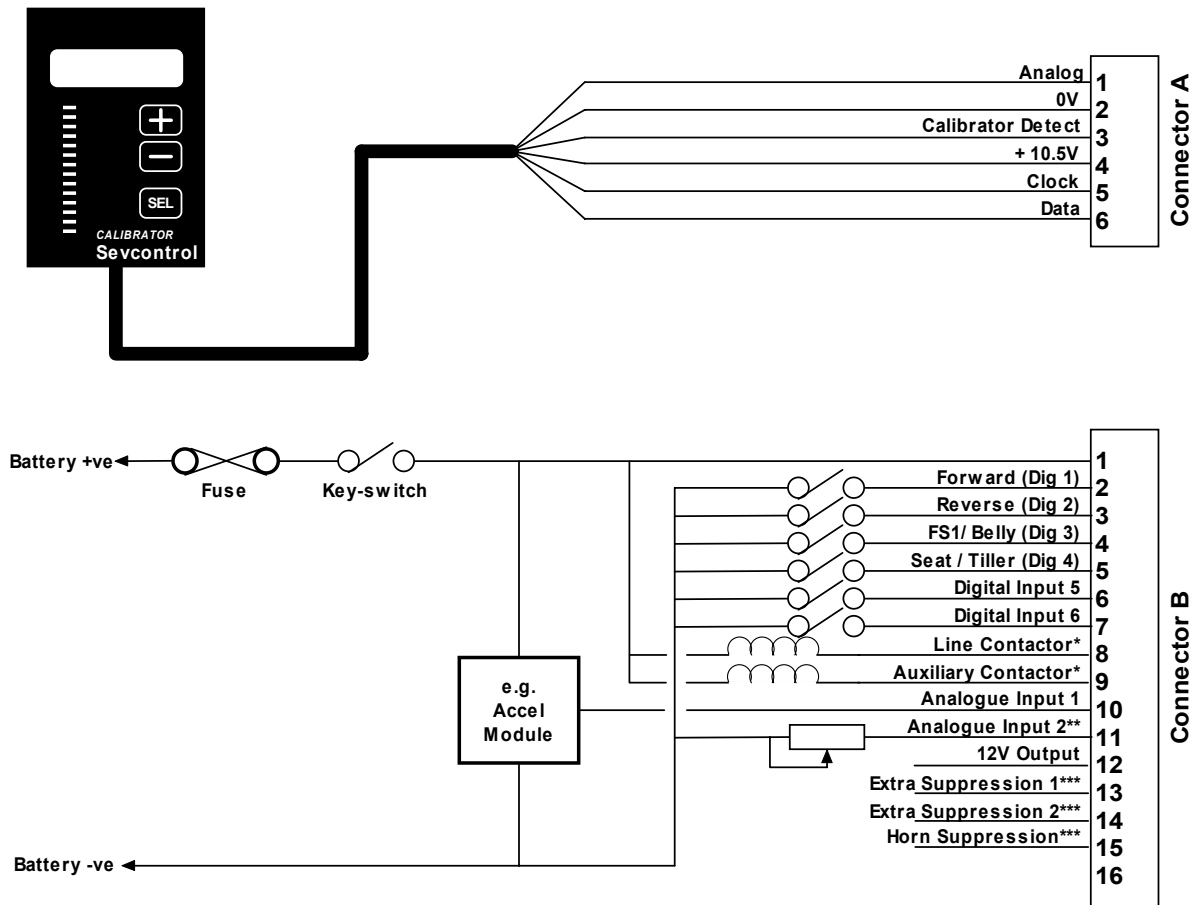

Figure 2: MillipaK 4QPM Power Wiring

NOTE: The Pump MOSFET's are optional (soft start versions only).

MillipaK Light Wiring example



NOTES:

- *Contactor Coil Suppression fitted internally.
- **Analogue Input 2 can also be configured as a digital input.
- ***Extra Suppression and Horn Suppression inputs to be used as shown below :

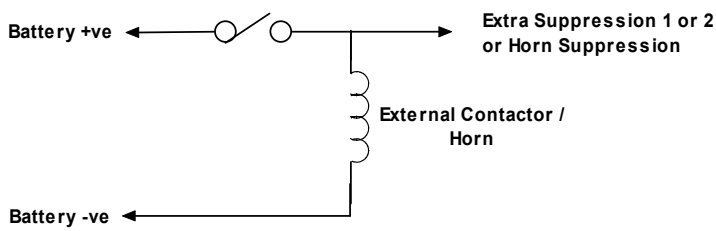

Figure 3: MillipaK Light Wiring

NOTES:

The line and auxiliary contactors are wired to B+, on the switched side of the key-switch.

The second analogue input on pin 11 is also available for use as a digital input. See system configuration section for how to configure the second analogue input as a digital switch input.

Pin 12 is available for 100mA supply, typically used for (but not limited to) accelerator modules.

Pins 13,14 & 15 are general-purpose suppression connections and may be used to suppress spikes generated by contactors opening / closing. The internal configuration is shown below:

Pin 16 is used to select FLASH memory program update mode and should normally be left unconnected.

Line contactor is required. 24-volt default setting.

If not using seat switch (Pin 5), replace switch with jumper wire to B-.

Pin 4 should not be connected until after controller is turned on.

Controller should be mounted to a paint free metal surface with thermal transfer grease.

Accelerator potentiometer should travel from 0 to 5k for Min to Max speed.

Fuses are recommended in case of wiring short circuit.

Calibrator

The Calibrator is a hand-held adjustment unit which can be used to configure and test the system. The MillipaK is designed to work with the Calibrator currently in use with SEVCON's MOS90 system. See diagram below. The menu structure is shown in the Calibrator Map located near the end of this manual.

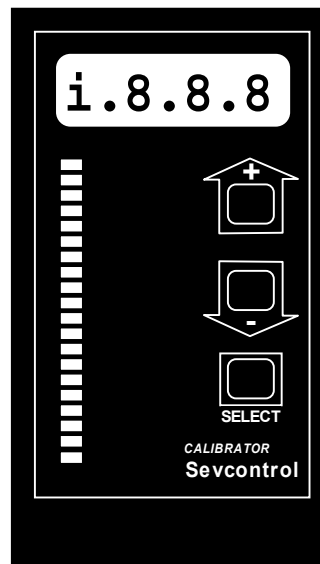

Figure 4: MillipaK Calibrator

Traction Drive Hours Counter

When the Calibrator is first plugged into the unit after power up, the Calibrator shows the Traction Drive Hours Counter. Refer to the Traction Drive Hours Counter section for more information on this function.

With no buttons pressed, the number displayed shows the number of minutes (accurate to 0.5 minutes). Pressing the '-' button displays the number of hours under 1000 and pressing the '-' button displays the number of 1000 x hours.

For example, if the hours counter was 12, 345 hours, 13 minutes and 40 seconds, with no buttons pressed, the display would show 13.5. Minutes are only shown to the nearest 0.5 minutes. If the '-' button was pressed, the display would show 345 (number of hours under 1000) and if the '+' button was pressed, the display would show 12 (number of 1000 x hours).

This is the only time that the hours counter can be viewed. Once the Select button has been pressed to enter the normal calibrator menu structure, it is not possible to return to this point. To view the hours counter again, you must recycle the Keyswitch.

This is also the point at which you can enter a password to enable different levels of access to personalities. Refer to the section below on Calibrator Security Levels for more details.

Calibrator Security Levels

Which personalities and status items which can be viewed on the Calibrator is restricted using passwords. There are three levels of Calibrator access. These are shown in Table 1.

Access Level	Text	Password	Description
Service	Ser	-	Default. This level is selected when no password or an invalid password is entered. Only items shown in the Calibrator Map with a thick solid border are displayed.
Engineering	Eng	1645	All items, except those in the Setup menu, can be displayed.
All Adjust	All	Contact SEVCON	All items are be displayed, regardless of configuration.

Table 1: Calibrator Security Levels

Note, for Service and Engineering security levels only items appropriate to the current system configuration are displayed. For example, if none of the switch inputs are configured as a Cutback 1 Speed Switch, then the Cutback 1 Speed personality will not be displayed.

The All Adjust security level allows access to all personalities, including those not required by the current configuration. The items in the Setup menu can only be accessed at this security level.

The password can only be entered just after power up when the Traction Drive Hours Counter is displayed. The '+' and '-' buttons are used to enter the password. The first digit is entered by pressing the '+' button the appropriate number of times (i.e. once to enter 1). The second digit is entered by pressing the '-' button the appropriate number of times (i.e. 6 times to enter 6). The third digit is entered using the '+' button again and the final digit is entered using the '-' button again. Note that when the '+' or '-' buttons are pressed, the display still changes to show hours or 1000 x hours.

When the password has been completely entered press either the '+' button or the SELECT button to initiate verification. If the password has been entered correctly, the text shown in Table 1 appropriate to the required level will be displayed for 1s indicating the password was accepted. If the password was incorrect or no password was entered, the system always defaults to Service mode.

After the Security Level has been displayed, the system enters the normal menu structure shown in the Calibrator Map. To change the password level, you need to recycle the Keyswitch.

Navigation

The Calibrator uses all three buttons for navigating through the menu structure.

Use the SELECT button to move through the menu structure. When the SELECT button is pressed the next menu item is displayed. The default direction is from left to right, top to bottom.

If the '+' and '-' buttons are held down together, the ID of the currently displayed menu item is shown. For example, if the Armature Current Limit personality was selected, then the ID would be 0.01 (menu 0, item 1). This allows the operator to locate where they are in the map.

If the '+' and '-' buttons are held down together for more than 3 seconds, the direction through the menu structure is reversed. Now when the SELECT button is pressed the direction is from right to left, bottom to top. In this mode, the LED on the Calibrator will flash. If the '+' and '-' buttons are held down together for more than 3 seconds again, the direction reverts back to the first direction and the Calibrator LED stops flashing.

The SELECT button is used to navigate through most of the menu structure, however, the Test menu (menu 19) is slightly different. Pressing the SELECT button will take you to the first item in the Test menu, (item 19.01 - Accelerator Demand). To navigate the Test menu, you need to use the '+' and '-' buttons. The '+' button moves up the Test menu and the '-' button moves back down. Pressing the SELECT button at any time exits the Test menu and moves to the first item in the menu structure (menu item 0.01 - Armature Current Limit).

The items which are displayed depends on the current system configuration and the Security Level.

Adjustments

Menus 0 to 12 are primarily used for configuring the system. All the personalities that the system uses to configure each function are in one of these menus. A brief description of the purpose of each menu is listed below. For more complete descriptions of each personality refer to the appropriate section in this manual.

Menu	Name	Purpose
0	Current Limits	Used to setup maximum currents for motor.
1	Braking Levels	Used to setup braking strength and performance.
2	Accelerator	Used to setup acceleration and deceleration performance and to configure the accelerator input voltage range.
3	Creep Speed	Used to setup creep speed.
4	Bypass	Not Used
5	Maximum Speed	Used to setup maximum speeds.
6	Cutback 1 Speed	Used to setup the speed for Cutback Speed 1.
7	Cutback 2 Speed	Used to setup the speed for Cutback Speed 2.
8	Motor Setup	Used to setup current control performance.
9	Power Steer Timer	Used to setup the Power Steer timer.
10	Seat Delay	Used to setup the Seat Switch debounce delay.
11	Additional Personalities	Used to setup additional personalities. These are personalities which do not belong in any of the menus shown above, or they are deemed to be unsuitable for modification by service engineers or end users.
12	System Setup	Used to configure the system at a high level. Items to configure the system I/O and performance are located in here. It is recommended that items in this menu are configured first before any of the other personalities. Unlike the personalities in the other menus, changes to items in this menu do not take affect until the Keyswitch is recycled.

Table 2: Adjustment Menus

Status and Test Information

Menus 13 to 19 are primarily used for providing information about the system. Every parameter which the system measures is located in one of these menus. A brief description of the purpose of each menu is listed below.

Menu	Name	Purpose
13	System Status	If there is a fault active in the system, this menu provides information about what the fault is. Refer to the Diagnostics section for more information.
14	-	Reserved for future use.
15	System Voltages	Used to display Battery and Capacitor Voltage measurements. The Battery Voltage measurement shows the voltage measured at the Keyswitch pin (pin 1 on connector B). The Capacitor Voltage measurement shows the voltage measured at the B+ terminal.
16	Motor Voltages	Used to show the voltage measured at the Point A terminals.
17	Motor Currents	Used to show the Armature Current Measurement.
18	Heatsink Temperature	Used to access the Heatsink Temperature measurement. Refer to the Temperature Monitoring section.
19	Test Menu	Used to access items which allow for testing of all the Analogue and Digital inputs available on connector B. Also displays unit information such as the Software Version, Controller Serial Number and the Personality Checksum. Refer to the appropriate sections for more information on each of these items.

Table 3: Status and Test Information Menus

Configuration

Configuration of the MillipaK controller is split into two categories – system and performance, which will be discussed in turn.

System Configuration

The MillipaK system configuration items relate to how the MillipaK will interface with connected hardware such as the system battery, vehicle control switches, accelerator and the traction motor.

System Voltage

The system voltage usually refers to the main system supply battery voltage. The controller uses this information to ensure low and high voltage settings are within an appropriate range.

System Voltage			Power Up
Calibrator Menu Reference:			12.18
Minimum	Maximum	Step Size	Default
24v	48v	2v	24v

System I/O Configuration

The digital inputs, analogue inputs and contactor drive outputs available on socket B can be configured in a number of ways to suit various applications. Table 4 shows a range of pre-determined settings which are available to the user and should cover the majority of applications, see below:

Digital I/O Value	Description
1	Walkie vehicle with Speed Cutback 1 switch, Pump Trigger switch and Electromagnetic Brake. Pump Trigger activates Pump Soft Start function.
2	Walkie vehicle with High Mast switch, Pump Trigger switch and Pump Contactor.
3	Walkie vehicle with High Mast switch, Pump Trigger switch and Electromagnetic Brake. Pump Trigger activates Pump Soft Start function.
4	Walkie vehicle with Speed Cutback 1 switch, Pump Trigger switch and Pump Contactor.
5	Walkie vehicle with Quick Pick switch, High Speed switch, Electromagnetic Brake and Hours Counter Drive.
6	Walkie vehicle with Pump Trigger switch, Brake Override switch, and Electromagnetic Brake.
7	Ride On vehicle with Speed Cutback 1 and 2 switches and external LED drive.
8	Ride On vehicle with Speed Cutback 1 switch, Handbrake switch and external LED drive.
9	Ride On vehicle with Handbrake switch, Power Steer Trigger switch and Power Steer Contactor.
10	Ride On vehicle with Speed Cutback 1 switch, Power Steer Trigger switch and Power Steer Contactor.
11	Ride On vehicle with Handbrake switch, Pump Trigger switch and Pump Contactor.
12	Ride On vehicle with Handbrake switch, Pump Trigger switch and Pump Contactor.
13	Ride On vehicle with Power Steer Trigger switch, Pump Trigger switch and Power Steer Contactor. Pump Trigger activates Pump Soft Start function.
14	Ride On vehicle with Traction Motor Overtemperature switch, Handbrake switch and external LED drive.
15	Ride On vehicle with Power Steer Trigger switch, Footbrake switch and Power Steer Contactor.
16	Ride On vehicle with Speed Cutback 1 and 2 switches and Reverse Alarm Buzzer drive.

Table 4: Description of each Digital I/O configuration.

WARNING: Incorrect configuration could cause a vehicle to move unexpectedly, for example if FS1 was inadvertently configured as a belly switch.

If your application doesn't fit any of the above, please contact Sevcon with details of your requirements.

Each of the above configurations allocates the controller i/o as shown below:

Digital Function	Value of Digital I/O Configuration Item															
	1	2	3	4	5	6	7	8	9	10	11	12	13	14	15	16
Forward	B2	B2	B2	B2	B2	B2	B2	B2	B2	B2	B2	B2	B2	B2	B2	B2
Reverse	B3	B3	B3	B3	B3	B3	B3	B3	B3	B3	B3	B3	B3	B3	B3	B3
Belly	B4	B4	B4	B4	B4	B4										
Tiller	B5	B5	B5	B5	B5	B5										
FS1							B4	B4	B4	B4	B4	B4	B4	B4	B4	B4
Seat							B5	B5	B5	B5	B5	B5	B5	B5	B5	B5
Speed Cutback 1	B6	B6					B6	B6		B6						B6
Speed Cutback 2							B7									B7
Handbrake							B7	B7		B7				B7		
P. Steer Trigger									B6	B7			B6		B7	
Pump Trigger	B7	B7	B7	B7		B7					B6	B7	B7			
High Mast			B6	B6												
Motor Over Temp														B6		
High Speed					B6											
Quick Pick					B7											
Brk Override Sw						B6										
Footbrake Sw															B6	
Line Contactor	B8	B8	B8	B8	B8	B8	B8	B8	B8	B8	B8	B8	B8	B8	B8	B8
P. Steer Contactor									B9	B9			B9		B9	
Pump Contactor		B9		B9							B9	B9				
Electro Brake	B9		B9			B9										
External LED							B9	B9						B9		
Bypass					B9											
Hours Counter																
Reverse Buzzer																B9

Table 5: Digital Functions

Notes:

1. Bx refers to Socket B pin numbers.
2. All vehicles have Forward and Reverse Switches and a Line Contactor.
3. All Walkie vehicles have Belly and Tiller Switches.
4. All Ride On vehicles have FS1 and Seat Switches.
5. Pump Trigger will trigger Pump Soft Start function as well as the Pump Contactor. This is why some configurations have a Pump Trigger but no corresponding Pump Contactor.

Analogue Functions

Analogue Function	Value of Analogue Input Configuration Item			
	1	2	3	4
Accelerator	B10	B11	-	B10
Footbrake			-	B11

Table 6: Analogue Functions**Notes:**

1. Bx refers to Socket B pin numbers.
2. All vehicles have an Accelerator input.
3. Analogue Input 3 is reserved for future use.

Table 6 details which analogue functions are configured for each value of the Analogue Input Configuration Item.

Digital Configuration			Power Up
Calibrator Menu Reference:			12.16
Minimum	Maximum	Step Size	Default
1	16	1	As Required

Analogue Configuration			Power Up
Calibrator Menu Reference:			12.17
Minimum	Maximum	Step Size	Default
1	4	1	As Required

System / Motor Set-up

There are various settings available to the user to tailor the MillipaK controller to specific motors and applications.

Armature Current Limit

The armature current limit personality is provided to allow the user to limit the maximum current supplied to the motor to a value lower than the peak rating of the controller.

Armature Current Limit			Immediate
Calibrator Menu Reference:			0.01
Minimum	Maximum	Step Size	Typical Value
50A	ABR	10A	ABR

ABR – Armature **B**lock **R**ating refers to the controller maximum peak current.

The above personality allows the armature current limit to be set. The actual armature current limit control is performed using a control loop. The following two personalities can be used to setup this control loop.

Current Limit Prop Gain			Immediate
Calibrator Menu Reference:			8.01
Minimum	Maximum	Step Size	Typical Value
0	255	1	As set

Current Limit Int Gain			Immediate
Calibrator Menu Reference:			8.02
Minimum	Maximum	Step Size	Typical Value
0	255	1	As set

WARNING: Seek advice from SEVCON before changing these two personality values. Changing these can affect the capability of the current limit function which could damage the unit due to over-current. The factory set values should be suitable for most applications

Contactor chopping

This feature allows 24 V contactors to be used at all battery voltages 24V - 48V, by continuously monitoring the battery voltage and chopping the contactor output pins accordingly, to present an average voltage suitable for 24V coils. Chopping is selectable by the calibrator. Care must be taken to ensure that chopping is always selected if 24V contactors are being used on battery voltages higher than 24V. In applications > 24 volts contactors must be fitted with blow out magnets. Chopping can reduce the overall dissipation in the coils and allows only one set of contactors to be stocked for all battery voltages.

Chopping Frequency approx. = 667Hz (Slightly audible).

Typical contactor coil voltage during chopping = 16 volts.

Typical contactor coil voltage during energisation = 24 volts for 1 second.

There are 3 contactor chopping options available via the setup menu: Off, On and 24V. The off setting is used for nominal battery voltage coils, and the On setting is for 24V coils on higher voltage vehicles. Setting to 24V provides chopping for 24V coils and lamps without the drop to 16V after 1s.

Chop Select			Power Up
Calibrator Menu Reference:			12.01
Options			Default
OFF	ON	24V	OFF

Accelerator Full /Zero Setting

The accelerator/analogue inputs are flexible in the range of signal sources they can accommodate and can be adjusted to minimise dead-bands and mechanical tolerances. Each analogue input has 2 adjustments associated with it to allow the input voltage range to be determined.

For the Traction Accelerator, for example, the 2 adjustments are called the “Accelerator Zero Level” and the “Accelerator Full Level”. If these were set to 0.20V and 4.80V then 0% pulsing would start at 0.20V at the input, increasing to 100% pulsing at 4.80V. For accelerators with decreasing voltage outputs, the Zero adjustment might be set to 3.5V and the Full adjustment to 0.0V. The Calibrator test menu shows the instantaneous voltage reading, and the equivalent % “push” for each input.

Accelerator Zero Volts			Immediate
Calibrator Menu Reference:			2.03
Minimum	Maximum	Step Size	Typical Value
0.00V	4.50V	0.02V	0.10V

Accelerator Full Volts			Immediate
Calibrator Menu Reference:			2.04
Minimum	Maximum	Step Size	Typical Value
0.00V	4.50V	0.02V	3.50V

Note that a 6 flash fault will occur if the full and zero levels are set within 0.50V of each other.

The PWM demand will vary between the Creep level and Maximum Speed level as the accelerator voltage varies between “Accelerator Zero” and “Accelerator Full”.

Performance

Various parameters may be adjusted to tailor the performance of the vehicle to customer requirements.

Acceleration Delay

This is an adjustable delay to ramp up the pulsing from 0% on to 100% on, and can be used to ensure smooth acceleration.

Acceleration Delay			Immediate
Calibrator Menu Reference:			2.01
Minimum	Maximum	Step Size	Typical Value
0.1S	5.0S	0.1S	1.5S

Deceleration Delay

This is an adjustable delay to ramp down the pulsing from 100% on to 0% on, and can be used to provide a smooth reduction of power to the motor.

Deceleration Delay			Immediate
Calibrator Menu Reference:			2.02
Minimum	Maximum	Step Size	Typical Value
0.1S	0.5S	0.1S	0.1S

Control Mode

The method of motor control may be switched between Torque and Speed control.

Control Mode	Power Up	
Calibrator Menu Reference:	12.03	
Options	Default	
Torque	Speed	Torque

Currently only torque control mode is available.

Regen Braking

All braking types are implemented using regenerative braking in the 4QPM MillipaK.

Braking can be initiated in one of 3 ways:

- (i) **Direction Braking.** Initiated when the direction switch inputs are reversed during drive. i.e., Reverse is selected when driving in Forward or Forward is selected when driving in Reverse.
- (ii) **Footbrake Braking.** Initiated when the operator depresses the Footbrake pedal and a footbrake input is configured. See section below for more information about setting up and configuring the system for Footbraking.
- (iii) **Neutral braking.** Initiated when the vehicle is put into neutral during drive and neutral braking level is greater than 0%.

Braking Levels

Each Braking Type has its own personality for setting the required braking level. These are shown below:

Direction braking level			Immediate
Calibrator Menu Reference:			1.01
Minimum	Maximum	Step Size	Typical Value
5%	100%	1%	75%

Neutral braking level			Immediate
Calibrator Menu Reference:			1.02
Minimum	Maximum	Step Size	Typical Value
0%	100%	1%	10%

Footbrake braking level			Immediate
Calibrator Menu Reference:			1.03
Minimum	Maximum	Step Size	Typical Value
0%	100%	1%	0%

The three braking levels for direction, neutral and footbraking are used to determine the strength of the braking. Setting the level to 0% disables braking (Note: Direction Braking cannot be disabled), 1% sets the braking strength to minimum (weakest braking) and 100% sets the braking strength to maximum (strongest braking).

Braking Entry and Exit

The following two personalities can be used to setup the Braking Entry and Exit performance.

Start Voltage			Immediate
Calibrator Menu Reference:			1.04
Minimum	Maximum	Step Size	Typical Value
0	255	1	230

Finish Voltage			Immediate
Calibrator Menu Reference:			1.05
Minimum	Maximum	Step Size	Typical Value
230	255	1	250

The Start Voltage level is used to determine the initial voltage applied across the armature at the start of braking. This is used to 'kick-start' the motor into braking as quickly as possible. A value of 0 will apply a very low voltage across the armature at the start of braking and a value of 255 will apply approximately battery voltage across the armature at the start of braking. This voltage is maintained until the desired braking level is achieved, at which point the system will vary the voltage to maintain a constant braking torque.

The Finish Voltage level is used to determine when braking is finished. The lower this value, the earlier braking will exit. This personality should be set to give the desired exit performance both when braking to a stop (Neutral or Footbraking) or during a direction change, (Direction Braking). It is recommended that this personality is not set lower than the Start Voltage personality.

NOTE: The factory set values for the Start Voltage and Finish Voltage personalities should be suitable for most applications.

Footbraking

Footbraking can be initiated in one of two ways:

- Via an analogue input configured as a Footbrake Pot. Using a potentiometer allows the operator to vary the amount of braking they want. See below.
- Via a digital input configured as a Footbrake switch. When the switch is active, the system will brake at the footbrake level.

Footbrake Pot

If the system is configured to use a Footbrake Pot, then the system will allow the operator to vary the amount of footbraking depending on the position of the footbrake pedal. Similar to the Accelerator input there are 2 personalities which can be used to setup the input voltage range of the Footbrake Pot.

Footbrake Zero Volts			Immediate
Calibrator Menu Reference:			11.10
Minimum	Maximum	Step Size	Typical Value
0.00V	4.50V	0.02V	0.10V

Footbrake Full Volts			Immediate
Calibrator Menu Reference:			11.11
Minimum	Maximum	Step Size	Typical Value
0.00V	4.50V	0.02V	3.50V

As the input voltage varies from the Zero level to the Full level, the footbrake demand varies from 0% to 100%. When the footbrake demand is at 0%, there is no footbraking. As the footbrake demand increases from 1% to 100%, the braking level applied by the system increases from 50% of the Footbrake Level personality to 100% of the Footbrake Level personality.

For example, assume the system is configured to have a footbrake pot and the Footbrake Level personality is set to 60%. If the operator has not depressed the footbrake pedal, then the voltage into the controller will be outside of the Footbrake Zero Level personality and the footbrake demand will be 0%. There will be no Footbraking.

If the operator starts to press the footbrake pedal, then the footbrake demand will increase. When the demand increases above 0% the system will start braking and will set the braking effort according to the following formula:

$$\text{braking effort} = \left(\frac{\left(\frac{\text{footbrake demand}}{2} \right) + 50}{100} \right) \times \text{footbrake level personality}$$

So, for this example, at 1% demand the braking effort would be

$$\begin{aligned} \text{braking effort} &= \left(\frac{\left(\frac{1}{2} \right) + 50}{100} \right) \times 60 \\ &= 30\% \end{aligned}$$

and at 75% demand the braking effort would be

$$\begin{aligned} \text{braking effort} &= \left(\frac{\left(\frac{75}{2} \right) + 50}{100} \right) \times 60 \\ &= 52.5\% \end{aligned}$$

Footbrake Priority

Footbrake priority can be set to drive or brake and this determines the controller action in the case of the accelerator and footbrake pedal both being active at the same time.

Footbrake Priority	Power Up
Calibrator Menu Reference:	12.15
Options	
Default	
Drive	Drive
Brake	

Creep Speed

The Creep speed is adjustable and is used to select a minimum pulsing level as soon as drive is requested, to minimise delays and dead-bands. The motor voltage is rapidly ramped to the creep level (equivalent to a 100mS acceleration delay).

Creep Speed			Immediate
Calibrator Menu Reference:			3.01
Minimum	Maximum	Step Size	Typical Value
0%	25%	1%	0%

Maximum Speed

Adjustment limits the maximum applied %on to the armature.

Maximum Speed			Immediate
Calibrator Menu Reference:			5.01
Minimum	Maximum	Step Size	Typical Value
0%	100%	1%	100%

Accelerator Characteristics

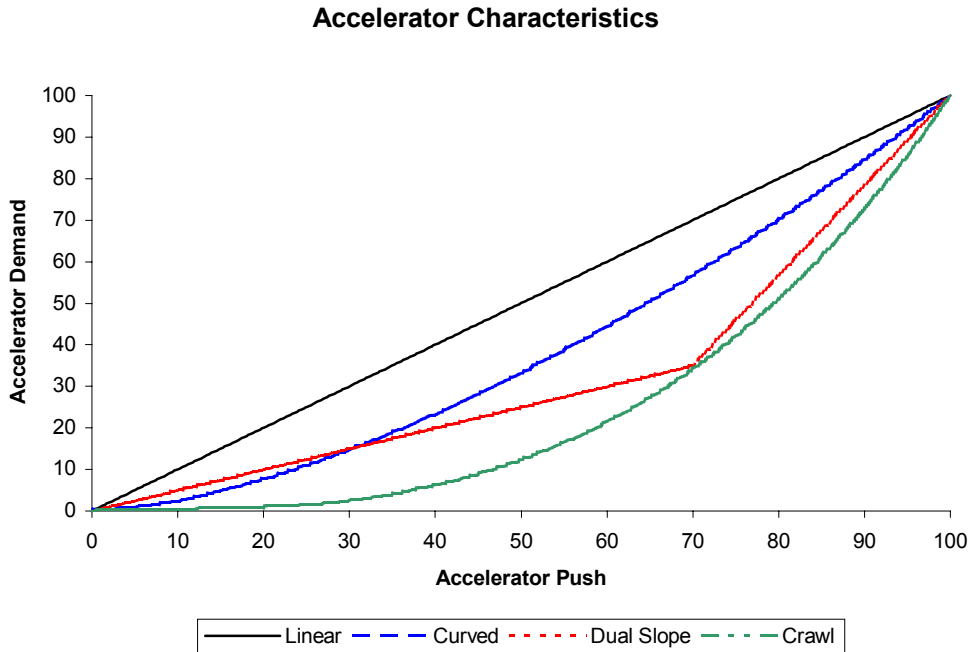

Figure 5: Accelerator Characteristics

Accelerator Characteristics				Power Up
Calibrator Menu Reference:				12.09
Options				Default
Linear	Curved	2*Slope	Crawl	Linear

This function is used to vary how much speed is demanded depending on the accelerator position. Setting either Curved, Dual Slope or Crawl gives a smaller change in speed for large changes in accelerator position and is useful for low speed maneuvering.

The accelerator push refers to how much the operator has the accelerator depressed. This is the value which is displayed on item 19.01 in the Test menu on the Calibrator. The Accelerator Demand refers to how much accelerator demand is requested after the Characteristic function is applied. This accelerator demand is then used along with the Creep Speed and Maximum Speed personalities to determine the speed demand for the vehicle.

If a valid direction is selected and the accelerator demand is at 0%, the speed demand will be set to the Creep Speed personality. As the accelerator demand is increased to 100%, the speed demand increases linearly to the Maximum Speed personality.

Examples:

1. The Accelerator Characteristic is set to Dual Slope, the Creep Speed personality is set to 0% and the Maximum Speed personality is set to 100%. If the accelerator push was at 70%, then the accelerator demand and the vehicle speed demand would be 35%.
2. Same conditions as (1) but the Creep Speed personality is set to 10% and the Maximum Speed is set to 75%. The accelerator push is still 70% and the accelerator demand is still 35%, but now the vehicle speed demand is 32.75%. i.e.:

$$\begin{aligned}\text{Speed Demand} &= \text{Creep Speed} + \left((\text{Maximum Speed} - \text{Creep Speed}) \times \frac{\text{Accelerator Demand}}{100} \right) \\ &= 10 + \left((75 - 10) \times \frac{35}{100} \right) \\ &= 32.75\%\end{aligned}$$

Features

The MillipaK controller has several features designed to offer the user maximum flexibility, safety and performance whilst ensuring the controller is protected against adverse or harsh driving conditions. These features can be split into three categories – standard controller features, safety features and controller protection features.

Standard Controller Features

The following section details the standard features found on a MillipaK controller.

Power Steer

A contactor drive is available to control a separate Power Steer motor. An adjustable delay allows the motor to operate for a set time, after the power steer trigger or power steer demand has been removed.

The following triggers are available and configurable for power steer:

Power Steer Trigger Configuration Item	Triggers		
	FS1 switch	Fwd or Rev switch	Seat switch
0	No	No	No
1	Yes	No	No
2	No	Yes	No
3	Yes	Yes	No
4	No	No	Yes
5	Yes	No	Yes
6	No	Yes	Yes
7	Yes	Yes	Yes

Table 7: Internal Power Steer Triggers

The software also monitors the motor for movement (if the Anti-Roll-Off feature is enabled) and activates the power steer driver accordingly.

Power Steer Personalities:

Power Steer Timer			Immediate
Calibrator Menu Reference:			9.01
Minimum	Maximum	Step Size	Typical Value
0S	60S	1S	2S

Power Steer Trigger			Power On
Calibrator Menu Reference:			12.14
Minimum	Maximum	Step Size	Default
0	7	1	0

See also contactor drive output configuration (System/Digital IO).

High Speed Switch and Anti-Tie Down

Vehicles with a High Speed Switch configured will normally drive at the Cutback 1 Speed, but will allow the maximum speed of the vehicle to increase to 100% in Reverse or the Cutback 2 Speed in Forward when the High Speed Switch is active. This is usually used for a Walkie type vehicle with a ride on platform where Reverse (Power unit forward, Forks trailing) is the normal driving direction.

This function has two modes, Normal and Momentary. Normal mode only activates this feature so long as the switch is active, Momentary mode activates this feature when the switch is active, and keeps the High Speed Operation active after the switch is released. High Speed Mode is configurable via the Calibrator.

High Speed Mode		Power On
Calibrator Menu Reference:		12.12
Options		Typical Value
Normal (NOR)	Latched (LAT)	Normal (NOR)

There are two separate options for High Speed Operation:

- **Normal (Unlatched).** High Speed Operation is only active when the switch is active.
- **Momentary (Latched).** High Speed Operation is active as soon as the switch is made active and remains active after the switch is released until any of the Anti-Tie Down conditions become true.

High Speed Operation will be activated when the following conditions are TRUE:

Normal mode:

- The High Speed Switch is active, and,
- Anti-Tie Down is not inhibiting the feature. Anti-Tie Down is used to prevent High Speed operation under conditions where the operator may not be expecting it.

Momentary mode:

- The High Speed Switch has been active at least once to initiate the function, and,
- Anti-Tie Down is not inhibiting the feature.

The speed demand in the Reverse direction (Power Unit Forward) is limited to the Cutback Speed 1 configuration item, if High Speed Operation is not active.

The speed demand in the Forward direction (Forks Forward) is limited to one of the following:

- The lower of the Cutback Speed 1 configuration item or the Cutback Speed 2 configuration item, if High Speed Operation is not active.
- The Cutback Speed 2 configuration item, if High Speed Operation is active.

Other speed demand limits may be applied whether High Speed Operation is active or not.

Anti-Tie Down inhibiting to the High Speed Switch Feature will be applied if any of the following conditions are TRUE:

- The system has just powered up.
- A change in direction has just occurred. i.e. The reverse direction is selected after the forward direction and vice versa.
- The Tiller Switch is inactive.

Anti-Tie Down inhibiting will be kept active until the High Speed Switch is cycled through its inactive state. Anti-Tie Down is used to prevent High Speed operation under conditions where the operator may not be expecting it.

Quick Pick

The Quick Pick function is used to drive a Walkie vehicle at a set speed in the Reverse direction (Power Unit First) when a switch is active on the Tiller arm. This feature is usually set up so that the vehicle will drive at walking speed. This allows the operator to drive the Walkie using one switch whilst they walk along side it.

Drive in the Reverse direction (Power Unit First) will be applied at a speed demand specified by the Walk Speed personality, when all the following conditions are TRUE:

- The Quick Pick switch is active.
- The Tiller switch is active.
- All Drive Switches Are Deselected.
- No Drive Inhibit or Severe faults are active.

The Walk Speed personality can be adjusted via the calibrator, i.e.

Walk Speed			Immediate
Calibrator Menu Reference:			11.02
Minimum	Maximum	Step Size	Typical Value
0%	100%	1%	As required

Quick Pick speed demand will be treated exactly the same way as a normal accelerator demand, where any cutbacks apply (Cutback Speeds, etc) and the demand will be treated appropriately in both Torque and Speed Control modes.

The following inputs will be ignored during Quick Pick operation:

- Forward Switch.
- Reverse Switch.
- FS1 Switch.
- Accelerator Demand.

Belly operation will still be allowed when the Quick Pick function is active.

Drive will be allowed after the Quick Pick switch is released only if all Drive Switches are Deselected. For example, if the Forward switch is activated during the Quick Pick operation, Drive is inhibited when the Quick Pick switch is released until the Forward switch is deactivated.

Seat Switch

If the seat switch is opened and the seat switch timer has timed out during drive the controller will stop pulsing and a seat fault will be indicated. Before drive can be restarted the seat switch must be closed, and FS1 and the direction switch must be recycled through neutral. Note the start sequence for drive requires that the seat switch is closed and both the direction and FS1 switches are in the neutral position simultaneously before drive can be initiated. The time period is programmed by means of the Calibrator (Seat Switch Delay). As a setup menu option the seat switch can also inhibit pump operation if required.

Seat Delay			Immediate
Calibrator Menu Reference:			10.01
Minimum	Maximum	Step Size	Typical Value
0.1S	5.0S	0.1S	5.0S

Seat Cuts Pump		Power On
Calibrator Menu Reference:		12.04
Options		Typical Value
OFF	ON	OFF

Handbrake Switch

An input is provided for the connection of a handbrake switch, which if operated will disable armature pulsing.

Cutback speeds

There are 2 cutback switch inputs as standard. Each one has an associated personality to adjust the maximum % on when the switch is active. When both switches are active together, the lower speed is selected. The cutback speed inputs are usually normally closed so that a wire off type fault or bad connection initiates a lower speed.

Cutback Speed 1			Immediate
Calibrator Menu Reference:			6.01
Minimum	Maximum	Step Size	Typical Value
0%	100%	1%	100%

Cutback Speed 2			Immediate
Calibrator Menu Reference:			7.01
Minimum	Maximum	Step Size	Typical Value
0%	100%	1%	100%

Traction Drive Hours Meter

The MillipaK maintains a log of the number of hours during which the controller is providing Traction functionality. The Traction Drive Hours Meter runs whenever the vehicle is driving or braking. The current number of logged Traction hours can be viewed using the Calibrator. Refer to the Calibrator section for more information.

Reverse Speed

In some instances the maximum reverse speed of the vehicle is required to be slower than the forward speed. This can be achieved by enabling the reverse speed limit and setting the Maximum Reverse Speed personality accordingly.

Maximum Reverse Speed			Immediate
Calibrator Menu Reference:			5.02
Minimum	Maximum	Step Size	Typical Value
0%	100%	1%	100%

Reverse Speed Limit Enable		Power Up
Calibrator Menu Reference:		12.06
Options		Default
OFF	ON	OFF

Pump Soft Start

The MillipaK units may be fitted with a Pump Soft Start feature. This allows a pump motor (up to 120A) to be connected directly to the controller and eliminates the need for a contactor. It also has the added benefit of providing a ‘soft start’ to the pump motor by gently ramping up the voltage over a pre-determined period. After triggering the pump will remain active for as long as the trigger input remains active or the pre-set timer expires, whichever is the shorter.

Pump Soft Start Ramp Up Delay			Immediate
Calibrator Menu Reference:			11.04
Minimum	Maximum	Step Size	Typical Value
0.1S	5.0S	0.1S	1.0S

Pump Soft Start Timer			Immediate
Calibrator Menu Reference:			11.05
Minimum	Maximum	Step Size	Typical Value
0S	60S	1S	2S

WARNING: The pump soft start option, when fitted, is NOT current limited and care should be taken not to exceed the maximum current specified by the controller rating.

Reverse Buzzer

The Reverse Buzzer function is used to drive a warning buzzer when the vehicle is reversing. The function works by activating the Reverse Buzzer output whenever the Reverse Switch is active.

Line Contactor Drop out

The controller will close the line contactor once a successful power up sequence has been carried out, after which drive operation can be achieved. The line contactor will remain closed unless it is opened following a serious fault or power being disconnected.

A further configurable option is available where the line contactor is opened (dropped out) if no drive activity has occurred for a period exceeding 5 seconds. If drive operation is selected once the line has been opened then it will be closed again so that drive operation can occur. Line contactor dropout operation can be selected in the PERS set up:

Line Contactor Drop out	Power Up
Calibrator Menu Reference:	12.10
Options	
OFF	ON
Default	
OFF	

Safety Features

The features listed in this section are designed with the safety of the operator in mind.

Start Up Sequence

At keyswitch on, the Direction and FS1 switches must be in the neutral condition simultaneously at least once before drive can be selected. This is a safety feature to help prevent unexpected movement immediately after power up.

Alternatively, the system may be programmed only to check FS1 at power on. This option is programmable:

Direction Switch Checking		Power Up
Calibrator Menu Reference:		12.08
Options		Default
OFF	ON	OFF

FS1 Recycle

On some vehicles, such as Golf Cars it is desirable to force the driver to remove accelerator demand before allowing the vehicle to drive in the opposite direction than it has been travelling in. This feature is implemented as an option and is selected in the PERS setup:

FS1 Recycle		Power Up
Calibrator Menu Reference:		12.07
Options		Default
OFF	ON	OFF

SRO (Static return to off)

This feature is optional in the setup menu and when specified, forces the following sequences of switch inputs to be followed before drive is allowed: Keyswitch-Direction-FS1 or Keyswitch-FS1-Direction (within 2 seconds of FS1) . Any other sequence will not allow drive. Drive will be inhibited if FS1 is active for more than 2 seconds with no direction selected. In this case the FS1 will need to be recycled.

Static Return to Off		Power Up
Calibrator Menu Reference:		12.02
Options		Default
OFF	ON	OFF

Belly Switch

A Belly Switch function is available when the controller is used on a walkie type truck. The feature can be enabled in the setup menu. See this section and wiring diagrams for additional information. Basic operation is as follows:-

Truck moving in Reverse and activating the Belly Switch, accelerator in reverse position:-

- a) The controller applies 100% braking.
- b) The vehicle will accelerate in the Forward direction (Forks Forward) at full speed along the accelerator curve when the vehicle has stopped.
- c) All drive will cease after driving for the time given by the Belly Delay personality (See below).
- d) The controller will wait for neutral to be selected before drive will operate. If the Belly Switch is pressed again however, action starts at b) above.

The Belly operation may be set to NORMAL or CONTINUOUS. When set to NORMAL the vehicle will activate belly operation for the duration set by the personality Belly Delay (Calibrator Menu Item 11.03). When set to continuous the belly action will operate for as long as the Belly switch input is active.

Belly Delay			Immediate
Calibrator Menu Reference:			11.03
Minimum	Maximum	Step Size	Typical Value
0.1S	5.0S	0.1S	1.0S

Belly Style		Power Up
Calibrator Menu Reference:		12.13
Options		Default
Normal	Continuous	Normal

Anti-Rollback

This is a standard SEVCON feature and is used to help prevent roll back conditions on ramps. If the driver reselects the previous direction after a neutral condition, braking is not attempted, and full drive power is available to restart on a hill.

Anti-Rolloff

This feature is designed so that if a vehicle is powered up, without its handbrake applied, any non-drive condition on a gradient results in the vehicle braking slowly, in a controlled way, down a ramp without running away.

The Roll-Off Electro-brake option may be set so that the Electro-brake (if fitted & configured) is applied (brakes on) when Roll-Off is detected.

The Roll-Off strength is determined by the value of the Roll-Off Speed personality. 0% disables Roll-Off completely, 1% will apply maximum braking effort and 100% will apply minimum braking effort.

Roll-Off Speed			Immediate
Calibrator Menu Reference:			11.01
Minimum	Maximum	Step Size	Typical Value
0%	100%	1%	5%

Roll-Off E-Brake		Power On
Calibrator Menu Reference:		12.05
Options		Default
OFF	ON	OFF

Fail-safe

The controller's safety system includes a microprocessor watchdog which can detect software failure, and a hardware fail-safe system which can prevent dangerous runaway conditions in the event of certain hardware failures.

Every time the controller is powered-up, the software checks that the fail-safe circuit is able to switch off the MOSFETs and open the contactors.

Controller Protection Features

There are several in built features which are designed to protect the MillipaK controller from damage due to excessive load currents, voltages and prolonged periods of high demand.

Temperature Monitoring

If the temperature of either power frame exceeds 75°C its maximum available current will be reduced. Note, however, that if the set current limit is less than the maximum available current limit actual cutback will occur at progressively higher temperatures than 75°C. The thermal cutback ensures that the maximum heatsink temperature is limited to 90°C (See Figure 6). When actual cutback occurs the diagnostic LED will flash 8 times. Inspection of the calibrator fault messages will indicate which unit is in thermal cutback.

Thermal Cutback Characteristic

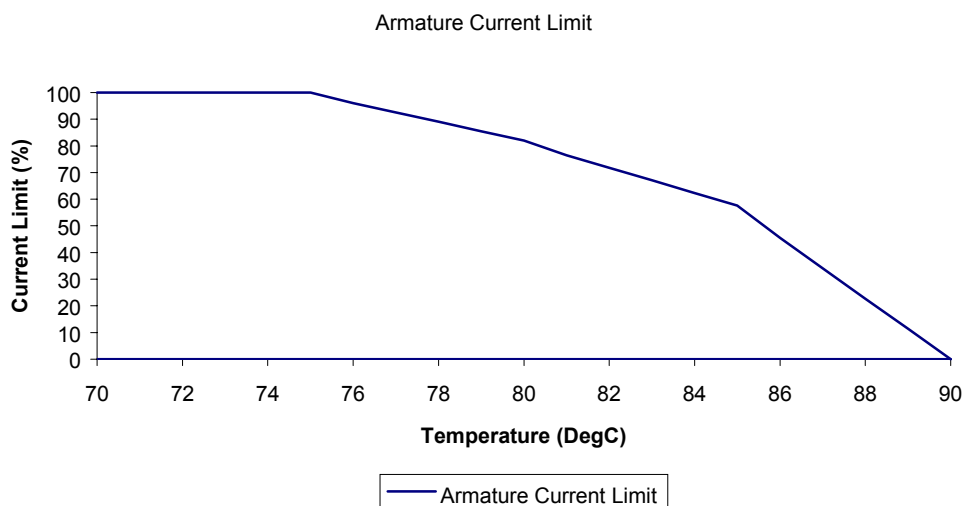

Figure 6: Armature Thermal Cutback Characteristic

Timed Current Cutback

During periods of high current usage the power components of the controller produce considerable heat. Under normal circumstances the controller will cutback the maximum current supplied to the load when the heatsink temperature rises above a safe level for the controller components. However, when the current supplied is close to the maximum rating of the controller the temperature rise of the components leads the heatsink temperature by up to 40°C. If this situation was allowed to arise damage may result in the controller. In order to prevent this situation a timed current cutback feature is incorporated in the MillipaK controller, which works as described below:

The controller monitors the load current during a 30 second period and categorises the value into low, medium, high or high & hot. The new current limit is then calculated as shown in Table 8.

Old Current Limit (% of ABR)	New Current Limit (% of ABR)			
	Low	Medium	High	High & Hot
100%	100%	90%	90%	60%
90%	100%	90%	80%	60%
80%	90%	80%	70%	60%
70%	80%	80%	60%	60%
60%	70%	70%	60%	60%

Table 8: Timed Current Limit Cutback Levels

ABR - Is the Armature Block Rating. The controller is deemed to be 'Hot' if the measured heatsink temperature is above 50°C.

The system will limit the current through the armature to the calculated limit during drive. The system will not apply any Timed Current Limit cutback during braking.

Motor Protection Cutback

By monitoring the motor current over a period of time, the controller then calculates the total power dissipation within a typical motor and so estimates the motor temperature rise.

After setting Motor Protection Cutback to ON, the estimated motor temperature can then be used to set the maximum allowed motor current and thus prevent excessively high motor temperatures being reached.

The maximum allowed motor current will reduce down to a minimum of 20% of the Armature Block rating if the estimated Motor Temperature rises to a dangerous level.

If Motor Protection Cutback is set to OFF then there will be no reduction in allowed maximum motor current due to estimated motor temperature, although any other forms of maximum current reduction (such as thermal cutback) will still be applied.

Motor Protection Cutback		Power Up
Calibrator Menu Reference:		12.09
Options		Default
OFF	ON	OFF

Safe Operating Area (SOA)

The controller’s current may be limited at high and/or low duty cycles depending on its current and voltage specification. This is to reduce the thermal stress on the power components in order to increase long term reliability. See Figure 7.

The “Safe Operating Area” is a characteristic of the MOSFETs and Freewheel Diodes which make up the power-frame. The MOSFET SOA restricts current at high duty cycles on all configurations, and the Diode SOA tends to restrict the current at lower duty cycles on lower voltage applications.

For most applications SOA will have little or no effect on the operation of the controller. Its effect is more significant in protecting the controller against adverse loads such as damaged motors and static test rigs.

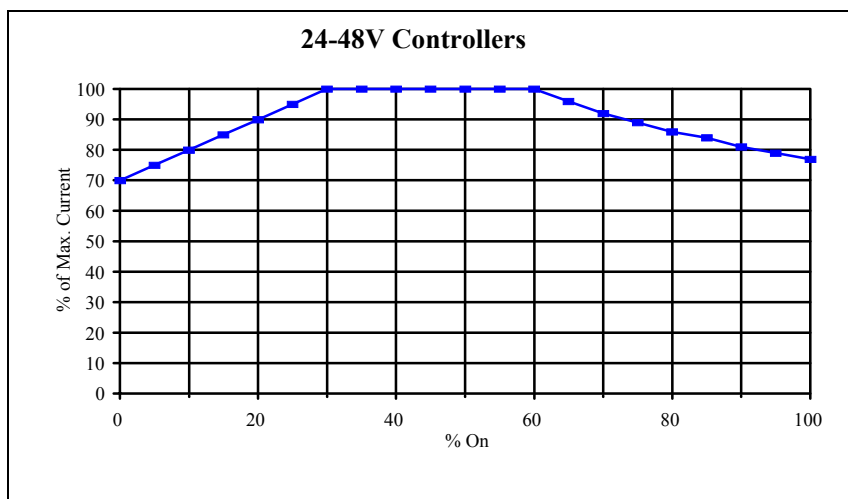

Figure 7: SOA Characteristic

Under-voltage and over-voltage protection

In order to prevent a sudden loss in power, the controller will begin to linearly ramp down the current limit, once the average battery voltage falls below a pre-set under-voltage start level. The current will be ramped down to 0 and a 7 flash fault indicated if the averaged battery voltage falls below the under-voltage cut-out level.

To protect the controller from over-voltage caused by prolonged regen braking, regen braking will be reduced when the average battery voltage reaches the over-voltage start level. If the voltage exceeds the over-voltage cut-out level in braking then the line contactors will open and freewheeling will occur, requiring the vehicles foundation brakes to be used.

Under any other circumstances if the battery voltage exceeds the over-voltage cut-out level, all pulsing is stopped and a 7-flash fault is indicated. This protects against incorrect battery connection.

Nominal Battery Voltage	Under-voltage Cutout	Under-Voltage Start (adjustable)	Over-voltage Start (adjustable)	Over-voltage Cut-out
24 V	14.5V	Under Voltage Cut-out up to System V	System V up to Over Voltage Cut-out	30.0V
36 V	14.5V			45.0V
48 V	14.5V			57.0 V

Table 9: Under and Over-Voltage Cutback Levels

The following calibrator menu items are used to set these values.

Low Voltage Start			Immediate
Calibrator Menu Reference:			11.06
Minimum	Maximum	Step Size	Typical Value
Low V Cutout	System Voltage	0.5V	18.0V

Low Voltage Cutout			Immediate
Calibrator Menu Reference:			11.07
Minimum	Maximum	Step Size	Typical Value
14.5V	Low V Start	0.5V	16.0V

High Voltage Start			Immediate
Calibrator Menu Reference:			11.08
Minimum	Maximum	Step Size	Typical Value
System Voltage	High V Cutout	0.5V	High V Cutout

High Voltage Cutout			Immediate
Calibrator Menu Reference:			11.09
Minimum	Maximum	Step Size	Typical Value
High V Start	50.0V or 58.0V	0.5V	50.0V or 58.0V

The maximum High Voltage Cutout depends on the level of the System Voltage item. If the System Voltage is set to 36V or lower, then the maximum is 50.0V. If the System Voltage is set greater than 36V, then the maximum is 58.0V.

Map for 4Q Controller System Version 1.01 - 6th September, 2001

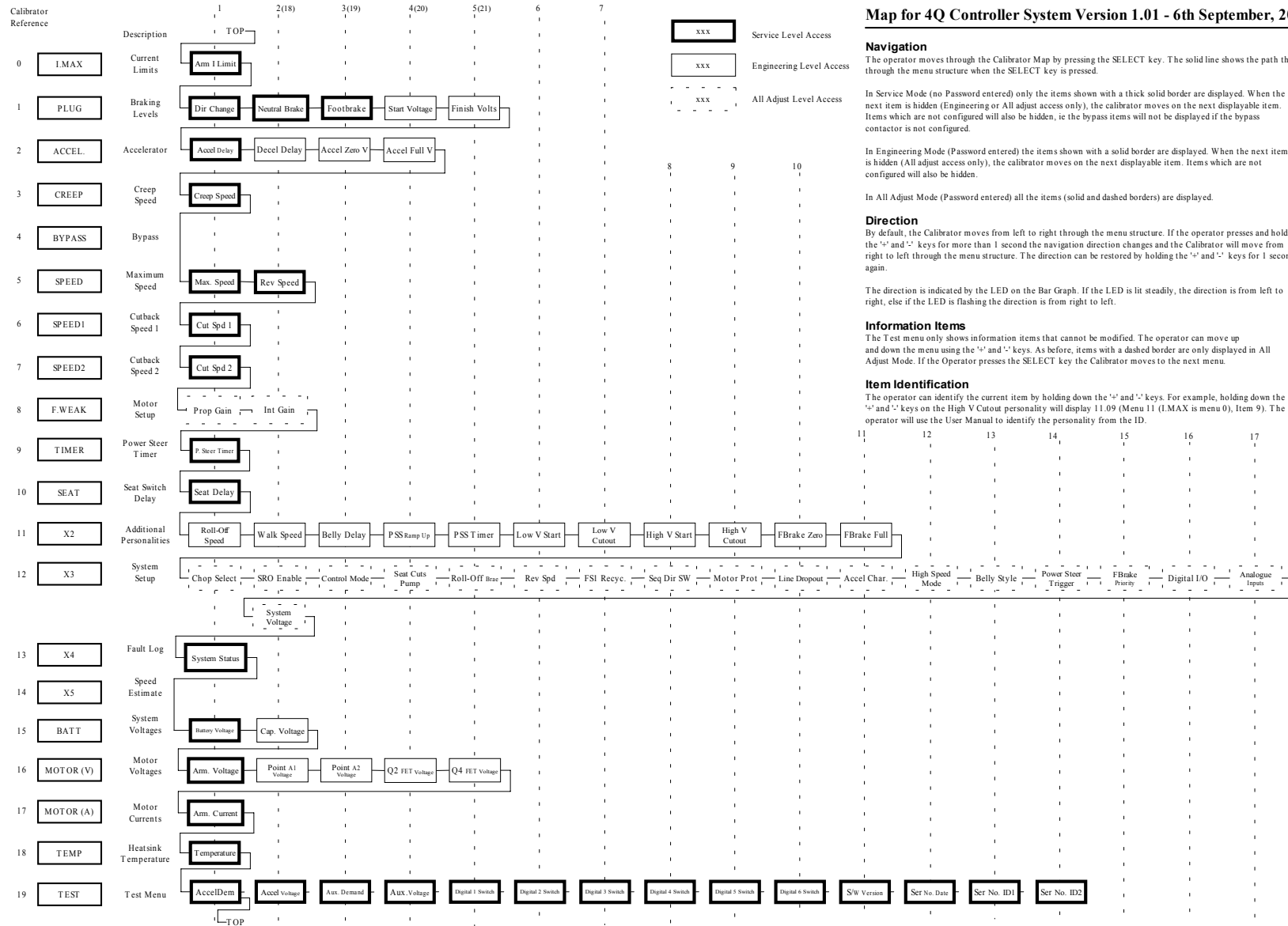

Commissioning Checklist

- Controller Mounted on suitable flat heatsink with appropriate heatsink compound ?
- Power wiring checked, shortest routes taken where possible ?
- Light wiring checked, use calibrator to verify controller correct switch operation.
- Accelerator set-up and checked 0 – 100% ?
- Personalities all set, checked and record filled out ?

Personality Record

	Personality	New Setting	Range	
			Minimum	Maximum
0.01	Armature Current Limit		50A	ABR ³
1.01	Direction Change Braking		5%	100%
1.02	Neutral Braking Level		0%	100%
1.03	Foot-brake Braking Level		0%	100%
1.04	Start Voltage		0	255
1.05	Finish Voltage		230	255
2.01	Acceleration Delay		0.1s	5.0s
2.02	Deceleration Delay		0.1s	0.5s
2.03	Accelerator Zero V ⁸		0.00V	4.50V
2.04	Accelerator Full V ^{8,9}		0.00V	4.50V
3.01	Creep Speed		0%	25%
5.01	Maximum Speed		0%	100%
5.02	Maximum Reverse Speed		0%	100%
6.01	Cutback Speed 1		0%	100%
7.01	Cutback Speed 2		0%	100%
8.01	Imax Proportional Gain		0	255
8.02	Imax Integral Gain		0	255
9.01	Power Steer Timer		0s	60s
10.01	Seat Delay		0.1s	5.0s
11.01	Roll-Off Speed		0%	100%
11.02	Walk Speed		0%	100%
11.03	Belly Delay		0.1s	5.0s
11.04	PSS Ramp Up Delay		0.1s	1.0s
11.05	PSS Timer		0s	10s
11.06	Low Voltage Start		Low V Cutout	System Voltage
11.07	Low Voltage Cutout		14.5V	Low V Start
11.08	High Voltage Start		System Voltage	High V Cutout
11.09	High Voltage Cutout		High V Start	50.0V or 70.0V ⁷
11.10	Foot Brake Zero Volts		0.00V	4.50V
11.11	Foot Brake Full Volts		0.00V	4.50V
12.01	Chop Select		OFF/ON/24V	
12.02	SRO Enable		OFF/ON	
12.03	Control Mode		TORQUE/SPEED	
12.04	Seat Cuts Pump		OFF/ON	
12.05	Roll-Off Electro brake		OFF/ON	
12.06	Reverse Speed Limit		OFF/ON	
12.07	FS1 recycle on Dir Change		OFF/ON	
12.08	Dir Sw Seq Checking		OFF/ON	
12.09	Motor Thermal Prot		OFF/ON	

	Personality	New Setting	Range	
			Minimum	Maximum
12.10	Line Cont Drop out		OFF/ON	
12.11	Accelerator Characteristics		LINEAR/CURVED/2*SLOPE/CRAWL	
12.12	High Speed Mode		NORMAL/MOMENTARY	
12.13	Belly Style		NORMAL/CONTINUOUS	
12.14	Power Steer Trigger		FS1/SEAT/DIRECTION/	
12.15	Foot-brake Priority		DRIVE/FOOTBRAKE	
12.16	Digital I/O		1	16
12.17	Analogue I/P		1	3
12.18	System Voltage		24V	48V

Table 10: Personality Record

Fault Finding

The MillipaK controller includes a number of features designed to help the user track down operational faults, wiring faults or internal controller faults.

The **Diagnostic LED** mounted next to the calibrator connectors on the front of the controller serves as a simple diagnostic tool as explained below:

ON	No fault, normal condition
OFF	Internal controller fault
1 flash	Personality out of range
2 flashes	Illegal start condition (Traction)
3 flashes	MOSFET Short Circuit
4 flashes	Contactora fault or Motor Open Circuit
5 flashes	Not used
6 flashes	Accelerator wire off fault
7 flashes	Low or High battery voltage or BDI cutout operating
8 flashes	Over temperature or timed cutback
10 flashes	Power Up Autozero has not yet been completed

Table 11: Flash Fault Descriptions

In addition to the LED indication a more detailed description of any faults detected may be found by using the calibrator. Menu item number 13.01 gives a code which corresponds to the following detected faults:

ID	Fault	Description	Flash Fault
0	System OK		On
1	Thermal Cutback	Maximum power available to the motor has been reduced due to excessive Heatsink temperature.	8
2	Timed Current Limit Cutback	Maximum power available to the motor has been reduced by the Timed Current Limit Cutback function.	8
3	Accelerator Wire Off	Input wire from accelerator has been disconnected.	6
4	Accelerator Pressed at Power Up	Accelerator pedal pressed at power up	6
5	Belly Fault	The Belly switch function has occurred	2
6	Seat Fault	Drive selected and no seat switch closed.	2
7	Autozero Not Taken	No drive allowed until power up autozero has been taken	10
8	FS1 Recycle	FS1 switch remained closed during a direction change	2
9	SRO Fault	Direction switch selected for greater than 2 seconds with FS1 open.	2

ID	Fault	Description	Flash Fault
10	Two Direction Fault	Two directions selected together.	2
11	Sequence Fault	Direction or FS1 switch cloaed at power up.	2
12	Low Battery Fault	Battery voltage is too low.	7
13	High Battery Fault	Battery voltage is too high.	7
14	High Battery Fault with Line Contactor Open	Battery voltage is too high before the line contactor is closed	7
15	Configuration Range Fault	A personality is out of range.	1
16	Configuration CRC Fault	The personality CRC is incorrect	1
17	Line Contactor Welded Fault	Line contactor is welded.	4
18	Line Contactor did not Close Fault	Line contactor is open circuit.	4
19	-	Reserved for future use	-
20	Lower MOSFETs Short Circuit	Short circuit on Q2/Q4 Armature MOSFETs detected.	3
21	VA Detect Fail	12V Supply Failure	0
22	MOSFET Off	MOSFETs did not pulse during power on failsafe checks (failsafe circuit enabled).	0
23	MOSFET On	MOSFETs pulsed during power on failsafe checks (failsafe circuit disabled).	0
24	Upper MOSFETs Short Circuit	Short circuit Q1/Q3 Armature MOSFETs detected.	3
25	Drive 2 Off	Contactactor 2 did not pulse during power on failsafe checks (failsafe circuit enabled).	0
26	Drive 2 On	Contactactor 2 pulsed during power on failsafe checks (failsafe circuit disabled).	0
27	Drive 1 Off	Contactactor 1 did not pulse during power on failsafe checks (failsafe circuit enabled).	0
28	Drive 1 On	Contactactor 1 pulsed during power on failsafe checks (failsafe circuit disabled).	0

Table 12: Fault Numbers and Descriptions

Fault Clearance

Any fault indication will be cleared by re-initiating the start sequence after the cause of the fault has been removed.

Fault Reporting Form

Sevcon is committed to improving the quality of all of its products. Please help us by using this form to report faults to Sevcon. Please give as much detail as possible. Use extra sheets if required. Fax this form to +44 191 482 4223.

Your Name		Telephone Number	
Your Company		email address	
Vehicle Manufacturer		Vehicle Type	
Controller Type		Part number	
Serial Number		Software Version	
Date / Time that fault first occurred.			
Exact Fault Message (calibrator or display)			
When did the fault message appear?	during drive / when the vehicle stopped / in neutral / after a keyswitch off-on (delete as applicable)		
How did the fault occur? Please describe: The vehicle speed. The approximate gradient (up or down hill) Pedal and switch changes by the driver What happened to the vehicle when the fault occurred			
What is the status of the vehicle now? Is there a fault message at key-switch on? Can it be driven?			

Table 13: Fault Reporting Form

Software Version and Serial Number indication

For identification purposes and to assist in queries, the Software version, and the controller serial number are indicated in the calibrator Test Menu.

The Software version is shown in the Test menu. When giving the Software Version, the entire number should be quoted (i.e. MM.mm).

The Serial Number is shown across three items in the Test menu. The first item is the date code and the next two are the identifier. All these items need to be used to get the complete serial number. The format is:

Test Item:	Ser No. Date	Ser No. ID1	Ser No. ID2
Serial Number:	MMYY	AA	BB

Table 14: Serial Number Format

MMYY gives the month and year when the controller was manufactured. (e.g. 0701 indicates July, 2001). AABB are combined to give a 4 digit identifier which is simply a number from 0001 to 9999. When giving the Serial Number, the entire number should be quoted (i.e. MMYYAABB).

The MillipaK range of controllers use the latest FLASH technology to allow In System Reprogramming. This is achieved without having to remove the controller from its installation – all that is needed is connection to the 6-way calibrator socket.

Specifications

The following specifications apply to all MillipaK controllers.

Power Configurations

At present the MillipaK 4Q controller is available in the following power configurations:

Housing	Armature	Soft Start Option
HP Large	330A	100A Soft Start

Table 15: Power Configurations

All the MillipaK 4Q range of controllers operate from 24-48v batteries.

WARNING: The pump soft start option, when fitted, is NOT current limited and care should be taken not to exceed the maximum current specified by the controller rating.

EMC standards

All MillipaK variants are tested to and conform to EN12895.

Socket B protection

All user connections on socket B are protected against indefinite short circuit to battery minus and battery positive.

Contactor drive ratings

All contactor drives are rated at 3A peak (10s) and 1.5A continuous. All the drives have reverse battery connection protection, inbuilt freewheel diode and are internally protected against short circuit.

Analogue Input Impedance

The two analogue inputs are internally pulled up to +12v via a 12k resistor. This is primarily designed for use with 5k potentiometers, but may also be used with suitable voltage sources.

Digital Input Impedance

The digital inputs are internally pulled up and are active LOW. They therefore must be connected to battery minus to operate a function. Maximum resistance to battery minus to operate is 500ohms.

EMC Guidelines

The following guidelines are intended to help vehicle manufacturers to meet the requirements of the EC directive 89/336/EEC for Electromagnetic Compatibility.

Any high speed switch is capable of generating harmonics at frequencies that are many multiples of its basic operating frequency. It is the objective of a good installation to contain or absorb the resultant emissions.

All wiring is capable of acting as a receiving or transmitting antenna. Wiring should be arranged to take maximum advantage of the structural metal work inherent in most vehicles. Vehicle metalwork should be electrically linked with conductive braids.

Power Cables

All cables should be routed within the vehicle framework and kept as low in the structure as is practical - a cable run within a main chassis member is better screened from the environment than one routed through or adjacent to an overhead guard.

Power cables should be kept short to minimise emitting and receiving surfaces

Shielding by the structure may not always be sufficient - cables run through metal shrouds may be required to contain emissions.

Parallel runs of cables in common circuits can serve to cancel emissions - the battery positive and negative cables following similar paths is an example.

Tie all cables into a fixed layout and do not deviate from the approved layout in production vehicles. A re-routed battery cable could negate any approvals obtained.

Signal Cables

All wiring harnesses should be kept short.

Wiring should be routed close to vehicle metalwork.

All signal wires should be kept clear of power cables or made from screened cable

Control wiring should be kept clear of power cables when it carries analogue information - for example, accelerator wiring.

Tie all wiring securely and ensure wiring always follows the same layout.

Controller

Thermal and EMC (emissive) requirements tend to be in opposition.

Additional insulation between the controller assembly and the vehicle frame work reduce capacitive coupling and hence emissions but tend to reduce thermal ratings. A working balance needs to be established by experiment.

The complete installation should be documented, in detail, and faithfully reproduced on all production vehicles. When making changes, consider their effect on compliance ahead of any consideration of cost reduction or other "improvement".

Ordering Information

The controllers and contactor panels are allocated 633 numbers as shown. The lettering section gives the full listing of item types.

item description	voltage	current	logic	Customer Code
A=	2= 24	1= 100-199	1= SEM plug	XX
B=	3= 36	2= 200-299	2= SEM plug s/start	
C= Controller only	4= 48	3= 300-399	3= SEM regen	
D= Traction panel	7= 72	4= 400-499	4= SEM regen s/start	
E= Traction + Pump Panel	8= 80	5= 500-599	5= Series Pump	
F= Twin Traction Panel	9= 96	6= 600-699	6=BPM	
G= Twin Traction + Pump Panel		7= 700-799	7=BPM s/start	
H=		8= 800-899	8= 4QPM	
J=		9= 900 +	9= 4QPM s/start	
K=				
L=				
M=				
N=				
P=				
R=				
S=				
T= HP Controller only				
W= HP Traction panel				
X= HP Traction + Pump Panel				
Y= HP Twin Traction Panel				
Z= HP Twin Traction + Pump Panel				

HP = High Power

For panels then the voltage, current and logic numbers should be used to describe the traction controller.

Examples:

330A 4QPM controller	633T43801
330A 4QPM controller with Soft Start	633T43901
600A SEM plugging controller	633T46101