

REVISIONS			
REV	ORIGINATOR	DESCRIPTION	APPROVED
A		INITIAL RELEASE	
B		Major revision	

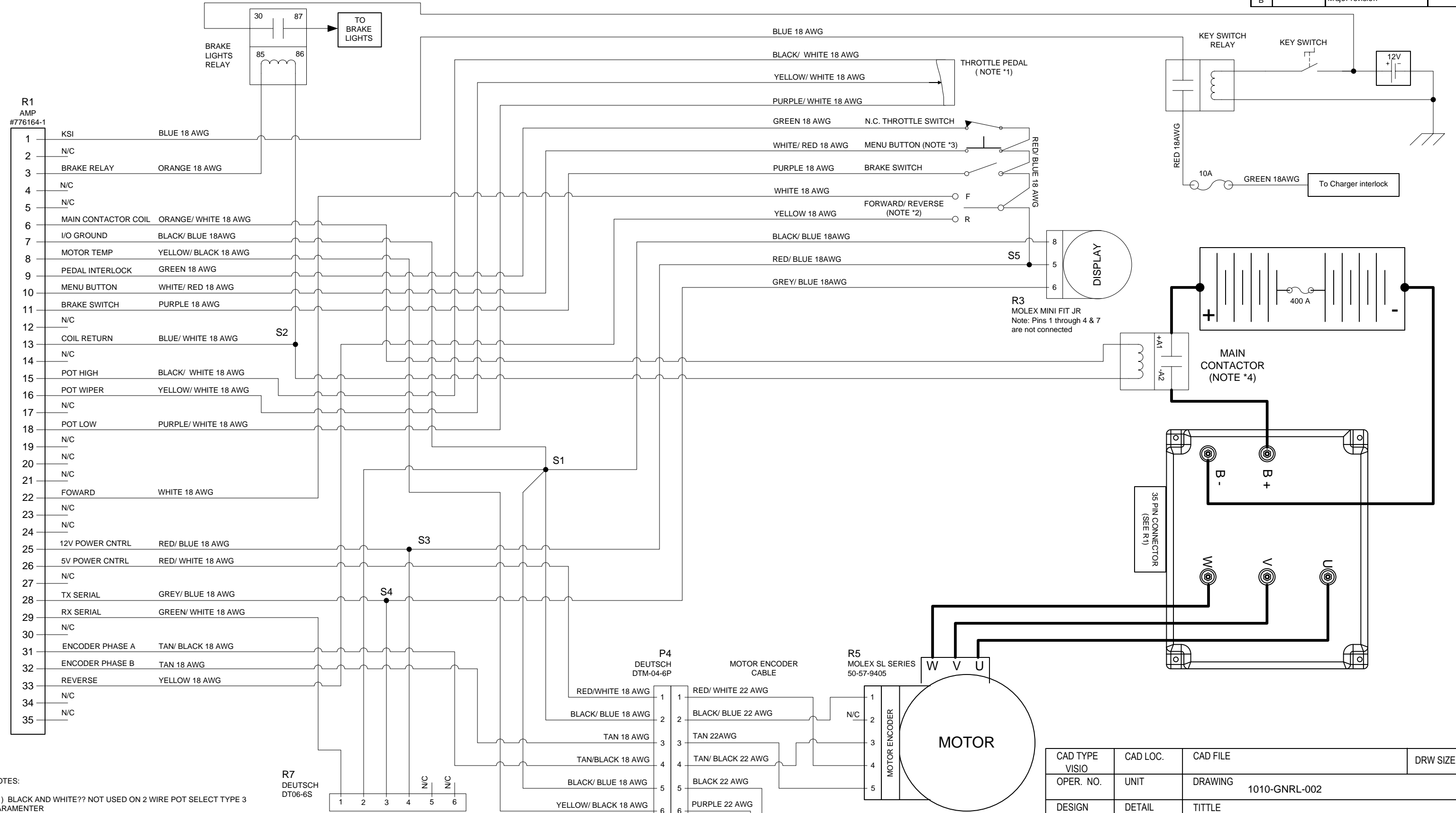

NOTES:
 (*1) BLACK AND WHITE?? NOT USED ON 2 WIRE POT SELECT TYPE 3 PARAMENTER
 (*2) IF REVERSES IS NOT USED, CONNECT WHITE WIRE TO RED/ BLUE
 (*3) MENU BUTTON IS OPTIONAL. USE WITH DISPLAY
 (*4) REMOVE ANY DIODES OR RESISTOR FROM MAIN CONTACTOR

CAD TYPE	CAD LOC.	CAD FILE	DRW SIZE B
VISIO	UNIT	DRAWING 1010-GNRL-002	
DESIGN	DETAIL	TITTLE	
CHECKED	SAFETY	BASIC GENERIC CAR SCHEMATICS	
SCALE	DATE	REVISION B	
	1/24/11	SHEET 1 OF 1	

REVISIONS			
REV	ORIGINATOR	DESCRIPTION	APPROVED
A		INITIAL RELEASE	
B		Major revision	

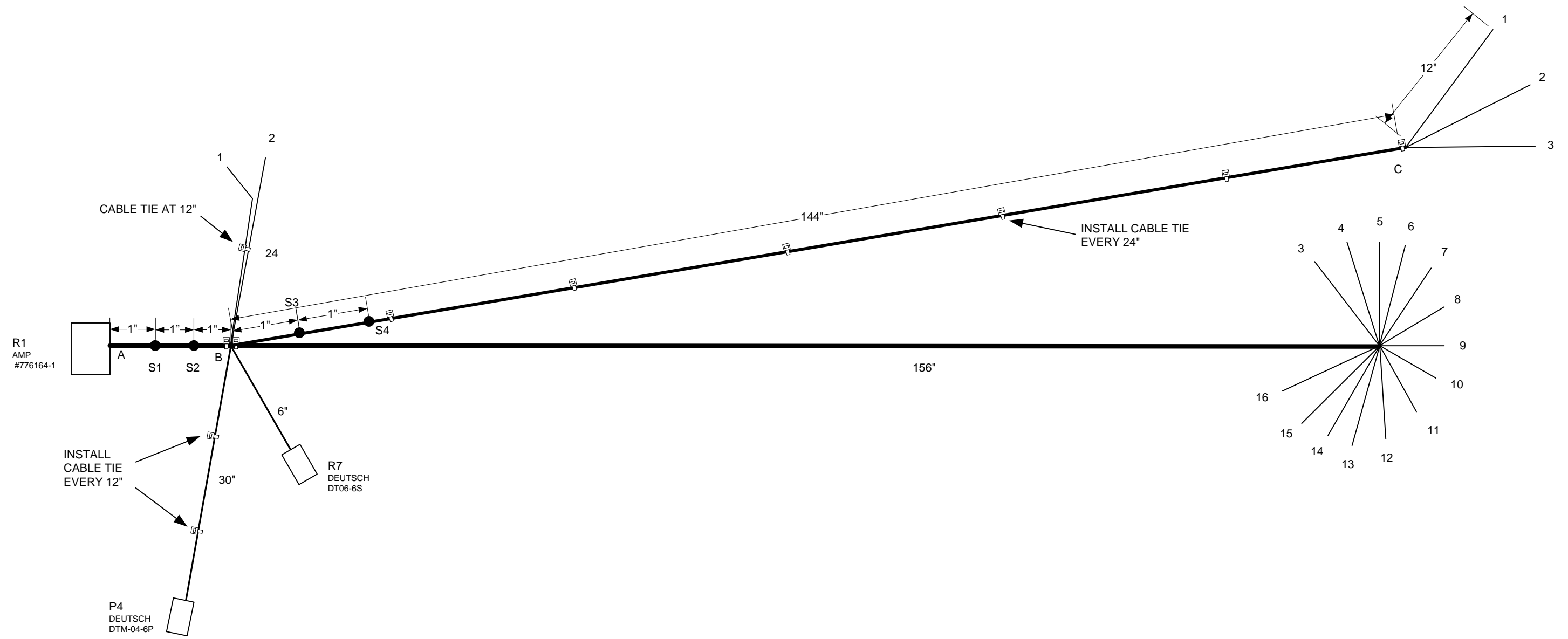

	TERMINAL	WIRE COLOR		TERMINAL	WIRE COLOR	
B1	NONE	BLUE/ WHITE		B9	NONE	BLACK/ WHITE
B2	NONE	ORANGE/ WHITE		B10	NONE	YELLOW/ WHITE
B3	NONE	BLUE		B11	NONE	PURPLE/ WHITE
B4	NONE	ORANGE		B12	NONE	WHITE
B5	NONE	BLUE/ WHITE		B13	NONE	YELLOW
B6	NONE	GREEN		C 1	NONE	BLACK/ BLUE
B7	NONE	WHITE/ RED		C2	NONE	RED/ BLUE
B8	NONE	PURPLE		C 3	NONE	GREY/ BLUE

NOTES:
 -ALL THE WIRES ARE 1007 STYLE
 -SPlice S5 IS PERFORMED BY THE END CUSTOMER

CAD TYPE VISIO	CAD LOC.	CAD FILE	DRW SIZE B
OPER. NO.	UNIT	DRAWING 1010-GNRL-002	
DESIGN	DETAIL	TITLE	
CHECKED	SAFETY	BASIC GENERIC CAR SCHEMATICS	
SCALE NONE	DATE 1/25/11	REVISION B	
		SHEET 1 OF 1	